

**PARTS INDEX**

POST RAILING SYSTEMS



HANDRAIL



HANDRAIL FITTINGS



POST  
HANDRAIL  
SUPPORT

WALL  
HANDRAIL  
SUPPORT

SADDLE



POST



TUBE/BAR INFILL

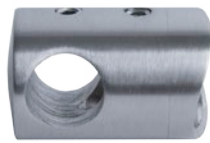

TUBE/BAR HOLDER



CABLE INFILL



GLASS CLAMP

GLASS RAILING SYSTEMS



GLASS CAP RAIL



GLASS CAP RAIL  
FITTINGS

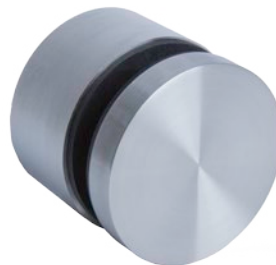



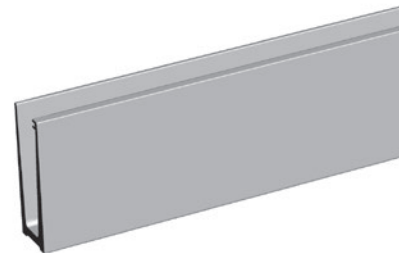





GLASS STANDOFFS



GLASS U-CHANNEL

## PARTS INDEX

### SYSTEM HARDWARE

	Quick#	Part#	Description	Application - Quantity Required
	250X	AX00.091.250.A.SP	M5 x 12 mm	Attaches saddle to metal handrail - 2 per
	540X	AX00.091.540.A.SP	4.8 x 25 mm	Attaches saddle to wood handrai - 2 per
	265X	AX00.091.265.A.SP	M6 x 10 mm	Attaches saddle to stem (Replacement) - 1 per
	260X	AX00.091.260.A.SP	M6 x 20 mm	Attaches bar holder to metal post - 1 per
	255X	AX00.091.255.A.SP	M8 x 25 mm	Attaches glass clamp to metal post - 1 per
	266X	AX00.091.266.A.SP	M5 Threaded Pop Rivet	Attaches glass clamp to metal post - 1 per
	267X	AX00.091.267.A.SP	M6 Threaded Pop Rivet	Attaches glass clamp to metal post - 1 per
	269X	AX00.091.269.A.SP	M8 Threaded Pop Rivet	Attaches glass clamp to metal post - 1 per

### ANCHORS

	Quick#	Part#	Description	Application - Quantity Required
	800X	AX00.091.800.A.SP	3/8 x 3-1/2" Wood lag bolts	Round newel post mount - 3 per Square newel post mount - 2 per
	805X	AX00.091.805.A.SP	3/8 x 3-3/4" Concrete wedge anchors	Round newel post mount - 3 per Square newel post mount - 2 per
	820X	AX00.091.820.A.SP	#10 x 3" Wood screw to attach to wall	Round wall mount flange - 3 per Square cap rail wall mount flange - 4 per Round cap rail wall mount flange - 4 per
	830X	AX00.091.830.A.SP	#14 x 3" Wood screw to attach to wall	Round adjustable angle wall rail fitting - 3 per Square adjustable angle wall rail fitting - 4 per Square wall mount flange - 4 per Round wall Rail return - 3 per Round side mount post bracket - 2 per Square side mount post bracket - 2 per
	855X	AX00.091.855.A.SP	#12 x 3" Flat head wood screw	Round wall Rail Bracket - 3 per Square wall Rail Bracket - 2 per
	880X	AX00.091.880.A.SP	1/2 x 2-1/2" Flat head drop in anchor	U Channel 90 degree corners - 2 per U Channel floor / wall mount (2500mm) U Channel floor / wall mount (5000mm)
	885X	AX00.091.885.A.SP	#14 x 3" Wood screw to attach to wall/floor (includes 3/8" washer)	
	900X	AX00.091.900.A.SP	M6 x 80 mm Wood screw with flat head(phillips)	Standoffs / side mount post brackets - 2 per
	905X	AX00.091.905.A.SP	M6 x 85 mm Machine screw with socket head	Standoffs / side mount post brackets - 2 per

PARTS INDEX

ADHESIVES & CLEANERS

Thread Lock

AX00.100.563



Anaerobic Adhesive

AX00.100.525



Two part epoxy

EPC-410



Epoxy gun

EPC-101



Clear Silicone Sealant

S-2611



Degreaser

AX00.080.515



Step 1

Cleaner/Polish

AX00.080.510



Step 2

Polish/Passivator

AX00.080.517



Step 3

Scotch Brite Pads

AX00.080.505



TOOLS & ACCESSORIES

Cutting fluid

AX00.070.652



Center punch

AX00.070.651



Shims (12 pack)

AX00.110.710



Sure Tite Newel Fastener

S-9403



Key Lock Newel Fastener

S-9401



Cable cutter (small)

HFC18.CUTTER



Cable cutter (large)

HFC18.C9CUTTER



Cable gripping pliers

HFC18.PLIERS



Cable cut-off wheel

HFC18.WHEEL



Push lock lag driver

DRIVER PL-LAG/R



Tension Gauge

HFC18.TENSION.GAUGE



Insert Tube

HFC18.TUBE



Cable Release Key

HFC18.KEY



## PARTS INDEX

## SPECIALITY TOOLS

## Infill tube bender

AX10.070.212



## Hydraulic Crimper

AX00.060.400



## Die set

AX00.060.415

AX00.060.420

Die set for 3-4mm

Die set for 5-6mm

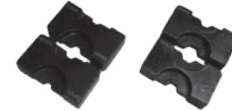

## Pop rivet gun

AX00.070.520



## Spanner wrench - round

AX30.070.530



## Spanner wrench - square

AX30.070.531



## Wedge tool

AX40.070.562



See our recommended tools section for information on cutting stainless steel. This section includes a complete range of tools that we highly recommend for professional installation.

[www.axiarailing.com/recommended-tools](http://www.axiarailing.com/recommended-tools)

## PARTS INDEX

### SWAGED CABLE INFILL KITS FOR WOOD OR METAL POSTS

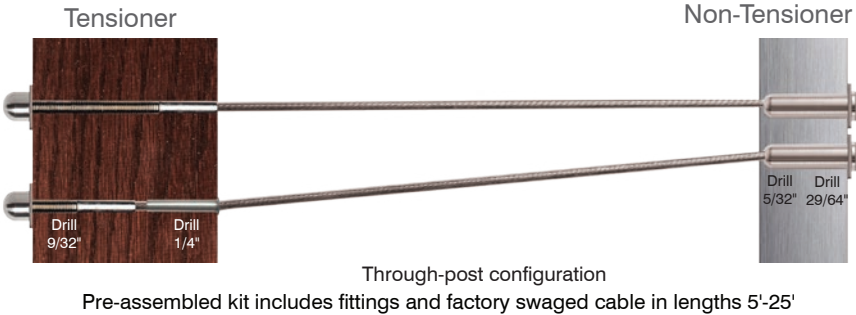

Outside to outside  
Level/balcony or angle/stair  
Steel or wood posts

<b>HFC18.102-5</b>	5'	.15 kgs (.331 lbs)
<b>HFC18.102-10</b>	10'	.227 kgs (.5 lbs)
<b>HFC18.102-15</b>	15'	.303 kgs (.669 lbs)
<b>HFC18.102-20</b>	20'	.383 kgs (.844 lbs)
<b>HFC18.102-25</b>	25'	.549 kgs (1.2 lbs)

Through-post configuration  
Pre-assembled kit includes fittings and factory swaged cable in lengths 5'-25'

**AX00.070.630**



**102 Wood Post Drill Kit**

**Includes:**  
5/32" Wood drill bit  
9/32" Wood drill bit  
29/64" Wood drill bit  
7/16" Open end wrench  
1/8" Allen wrench

**AX00.070.635**



**102 Metal Post Drill Kit**

**Includes:**  
5/32" Metal drill bit  
9/32" Metal drill bit  
29/64" Metal drill bit  
7/16" Open end wrench  
1/8" Allen wrench

Cable cutter(small)

**HFC18.CUTTER**



Cable cut-off wheel

**HFC18.WHEEL**



### CABLE INFILL - SWAGING REQUIRED - WOOD OR METAL POSTS



Outside to outside  
Level/balcony or angle/stair  
Steel or wood posts

**AX00.070.610**

**Bulk Cable & Fittings Drill Bit**



**Includes:**  
5/16" Kobalt drill bit  
10 mm Open end wrench  
8 mm Allen wrench

Cable cutter(small)

**HFC18.CUTTER**



Hydraulic Crimper

**AX00.060.400**





## PARTS INDEX

### SWAGELESS CABLE INFILL FOR WOOD OR METAL POSTS

#### Inside to inside Level/balcony or angle/stair Wood posts

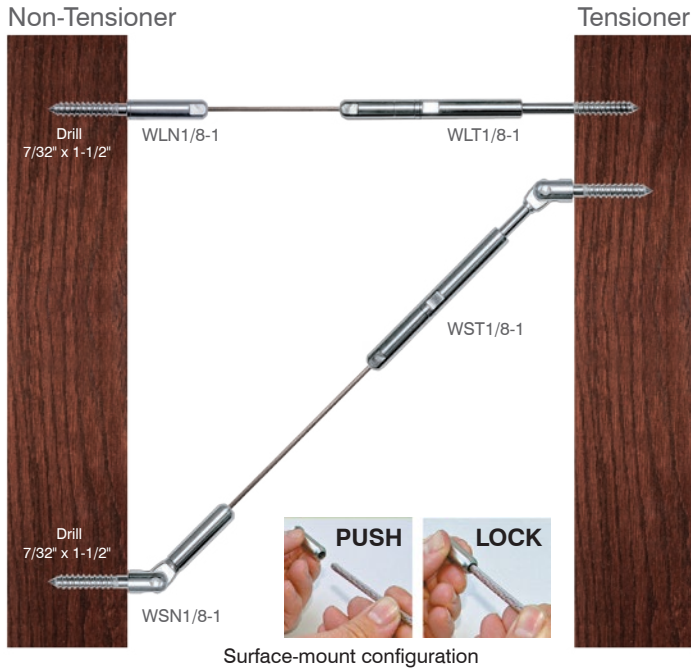

Surface-mount configuration

- WLN1/8-1** Wood Level Non Tensioner
- WLN1/8-10** Wood Level Non Tensioner(10 pack)
- WLT1/8-1** Wood Level Tensioner
- WLT1/8-10** Wood Level Tensioner(10 pack)
- WSN1/8-1** Wood Stair Non Tensioner
- WSN1/8-10** Wood Stair Non Tensioner(10 pack)
- WST1/8-1** Wood Stair Tensioner
- WST1/8-10** Wood Stair Tensioner(10 pack)

#### AX00.070.625

#### Wood Post Drill Kit

##### Includes:

- 5/32" Wood drill bit
- 7/32" Wood drill bit
- 3/8" Open end wrench
- 3/16" Allen wrench



#### Push lock lag driver

#### DRIVER PL-LAG/R



#### Cable cutter(small)

#### HFC18.CUTTER

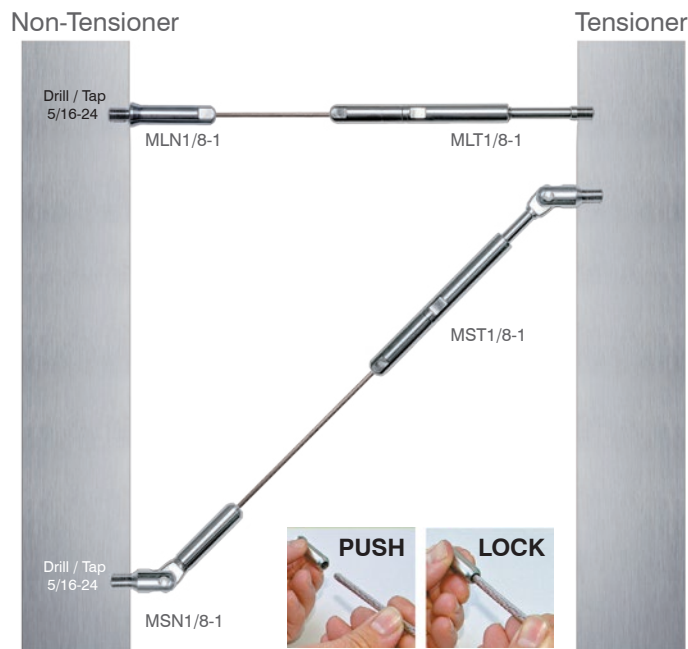

Surface-mount configuration

#### Inside to inside Level/balcony or angle/stair Metal posts

- MLN1/8-1** Metal Level Non Tensioner
- MLN1/8-10** Metal Level Non Tensioner(10 pack)
- MLT1/8-1** Metal Level Tensioner
- MLT1/8-10** Metal Level Tensioner(10 pack)
- MSN1/8-1** Metal Stair Non Tensioner
- MSN1/8-10** Metal Stair Non Tensioner(10 pack)
- MST1/8-1** Metal Stair Tensioner
- MST1/8-10** Metal Stair Tensioner(10 pack)

#### AX00.070.650

#### Metal Post Drill Kit

##### Includes:

- 5/16" Tap (24 thread)
- 5/16" Metal drill bit - Letter I
- 5/32" Metal drill bit
- 3/8" Open end wrench
- 3/16" Allen wrench



#### Cable cutter(small)

#### HFC18.CUTTER



## Cutting and Drilling Stainless Steel

### TOOLS REQUIRED

- **Stainless Steel Cutting Saw** (Cold Cut Saw, Bench top Portable Bandsaw, Chop Saw with Stainless Steel Cutting Blade)
- Cobalt Drill Bits
- Center Punch
- Cutting fluid

Complete tools list is provided on individual installation guides

For more detailed information on tools please visit:  
[www.axiarailing.com/recommended-tools](http://www.axiarailing.com/recommended-tools)



### GENERAL GUIDELINES

**Cutting Stainless Steel can be difficult if the correct tools and procedures are not followed!**

1. **Protect all stainless tubing with painters tape to keep from scratching during cutting and drilling. Blue 3M is recommended 2" wide**
2. Use a center punch and hammer at starting point into tubing before drilling.
3. **Use Cobalt drill bits for drilling stainless steel**
4. Drill a pilot hole for all holes using a 1/8" Cobalt bit, then drill with the final size bit.
5. **Use cutting fluid lubricant or other lubricant during cutting and drilling.**
6. Use cold cut saw or band saw for cutting tubing.
7. **Do not use any saw blades or drill bits that have previously been used on carbon steel. This will cross contaminate the stainless steel and cause it to rust.**
8. Keep bits and blades sharp by re-sharpening or replacing.
9. **Keep tubing, saw blades and drill bits cool during cutting and drilling. Apply cutting fluid or other lubricants liberally. Slow down the RPM's on the saw blade and drills, if you are seeing smoke or glowing, stop and apply lubricant and let cool.**

10. Stainless Steel hardens very quickly as you work the metal (get it hot) so keep all bits and blades cool with lubricant during cutting and drilling. This will also extend the life of the bits and saw blades.
11. **Apply 3 or 4 drops of cutting oil before tapping stainless tubing.**
12. Use deburring bits and die grinder to clean metal burrs inside the tubing.
13. **Use 1000-2000 up to 4000 grit sandpaper to sand stainless on exterior edge of cut on tubing. Do not bevel the cut with sandpaper. Sand stainless steel with the grain of the finish of the tubing.**
14. Use Scotch Brite pad or 1000, 2000, 4000 grit sandpaper to remove minor scratches on surface. Sand with the grain of the tubing.
15. **Use belt sander with 80 -120 grit belt sandpaper to grind on the end of tubing to make cuts flat if you are using a bandsaw to cut tubing.**
16. Formula to remember; Circumference = pi x Diameter  
E.G.  $C = 3.14 \times 1.66 = 5.2124 / 4 = 1.3031$  to each quadrant. Or  $1 \frac{9}{32}$ "  
This will allow you to measure accurately to place a glass clamp at 90 degree or 180 degree by Measuring with a flat tape measure around the newel. This is for  $1 \frac{11}{16}$ " round newel post.  
This is the most accurate way to drill glass clamps at 90 and 180 degrees on our 1.66" diameter round newel post.



## Cleaning and Maintenance of Stainless Steel

### TOOLS REQUIRED

- Cloth Rag
- Scotch Brite Pads (7447 General Hand Pad) (AX00.080.505)
- Degreaser (AX00.080.515)
- Cleaner/Polish (AX00.080.510)
- Polish/Passivator (AX00.080.517)

For more detailed information on tools please visit:  
[www.axiarailing.com/recommended-tools](http://www.axiarailing.com/recommended-tools)



### GENERAL GUIDELINES

Stainless steel is an iron and carbon alloy that is particularly corrosion resistant; the main reason is chrome presence, which can oxidize and create a thin film that can resist external chemical agents.

To keep this corrosion resistance, it is necessary to avoid the following actions:

- Storage near iron elements
- Use of same tools both for iron and stainless-steel items
- Inadequate treatment during the assembly
- Urban and fine dust pollution

AXIA STAIR & RAILING SYSTEMS® has developed a specific stainless-steel cleaning line, which is able to remove polluting elements, and able to recreate the original film protection. A combination of these products can clean a damaged surface. For ordinary cleaning, you can use damp soft rag with no solvent or abrasive material and carefully dry to avoid lime stains.

If more abrasion is needed to remove stains, rust etc. use Scotch Brite pad to remove the stain using the degreaser in conjunction with the Scotch Brite Pad. Be sure to rub the Scotch Brite pad with the grain of the stainless steel tubing.

- **Round tubing grain is circumferential**
- **Square tubing grain is longitudinal**
- **Cap rail and U Channel cladding grain is longitudinal**

Reapply the passivator once all blemishes and stains have been removed to promote the reestablishment of the oxidation layer on the stainless and prevent new staining.

AXIA STAIR & RAILING SYSTEMS® recommends cleaning stainless steel products at least once a year. In case of installation in highly polluted locations, such as cities or seaside resorts, it is necessary to do a thorough cleaning with AXIA STAIR & RAILING SYSTEMS® specific products every 1-2 months, or as soon as stains develop on the surface.

## STEPS REQUIRED

**Step-1** Clean all surfaces with degreaser to remove any oils, corrosion and stains from stainless steel. Use Scotch Brite pads in conjunction with degreaser to clean any rust, stains, scratches on stainless steel. Be sure to rub Scotch Brite pad with the grain of the stainless steel. **Once all is clean, rinse with clean water and dry thoroughly!**



Scotch Brite Pads

AX00.080.505



Step 1

Degreaser

AX00.080.515

**Step-2** Clean and polish with our stainless steel cleaner/polisher on all surfaces with soft clean rag.



Cloth Rag



Step 2

Cleaner/Polish

AX00.080.510

**Step-3** Apply passivator on stainless steel surface by using clean dry rag and apply passivator to rag and rub entire surface of stainless. Keep rag fully saturated with passivator but not dripping.

Once applied, do not rub off or clean off with any other cleaners. Any cleaning chemicals applied after passivator application will remove the passivation layer film.

Reapply passivator after each cleaning to prevent stains and rusting. Keep Scotch brite pads for removing stains and rust pits, etc. **DO NOT USE STEEL WOOL ON STAINLESS STEEL.**



Cloth Rag



Step 3 (required for exterior)

Polish/Passivator

AX00.080.517

## Post Railing Systems

### NEWEL POST INSTALLATION

AX10.001.001.A.SP	(1 11/16" Round Floor Mounted Newel Posts)
AX20.001.010.A.SP	(1 9/16" Square Floor Mounted Newel Posts)
AX00.091.800.A.SP	(3/8 X 3 1/2" Wood Lag Bolt)
AX00.091.805.A.SP	(3/8 X 3 3/4" Drop in"Anchor (for Concrete)

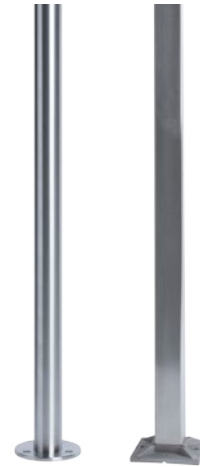

### TOOLS REQUIRED

- 4' Level
- 3/4" Socket and Ratchet
- 1/4" Wood Drill Bit
- Tape Measure
- Blue Painters Tape
- Stainless Steel Cutting Saw (Cold Cut Saw, Bench top Portable Bandsaw, Chop Saw with Stainless Steel Cutting Blade)

For more detailed information on tools please visit:  
[www.axiarailing.com/recommended-tools](http://www.axiarailing.com/recommended-tools)

### STEPS REQUIRED

**Pro Tip!** Before you do anything, cover all stainless posts with blue painters tape to protect from scratches, this will also provide a surface to mark locations for drilling with a fine point sharpie pen.

#### 1. Determine Newel Post length and cut to length

Determine height of rail desired e.g. 34"-38" for residential stairs and min. 36" for balcony residential

Remember to deduct the amount of length for the rail support to sit on top of the post plus the size of the handrail tubing. Ex. 36" rail height: 36" – 1 3/4" for rail support – 1 9/16" for handrail tubing

Total length of balcony post would equal 32 11/16" long. Note; don't forget to deduct any floor cap from length. Height should be measure from finished floor. (see fig.)

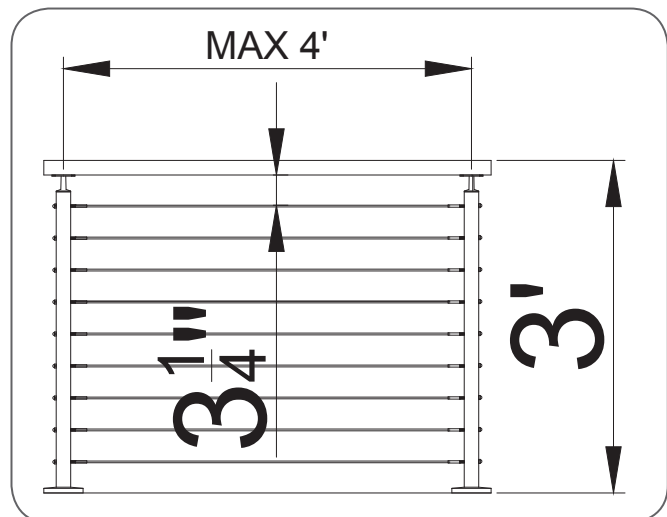
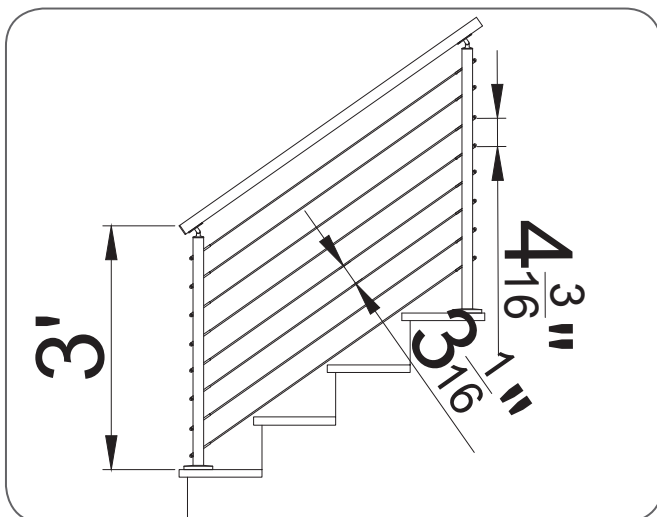

Cut at 90-degree angles exactly. To check fit of the cut slide rail support into tube and check gap between rail support and tube. If gap is more than a hairline gap and inconsistent around tube use a belt sander or grinder on top of newel post to grind the cut flat. During sanding/grinding check fit of rail support periodically as to not remove too much material.

## 2. Anchor newel posts to floor using appropriate anchor bolts e.g. wood lags for wood floor, concrete wedge anchors for concrete floor.

Drill Pilot 1/4" hole "the size of the shaft of the anchor bolt" in each hole of the Newel Post Flange (wood lags only) Drill 3/8" hole for concrete anchor bolts.

Be sure to align the newel post flange so that two screws on round posts are on the stair or balcony side of the railing parallel with the handrail to be installed.

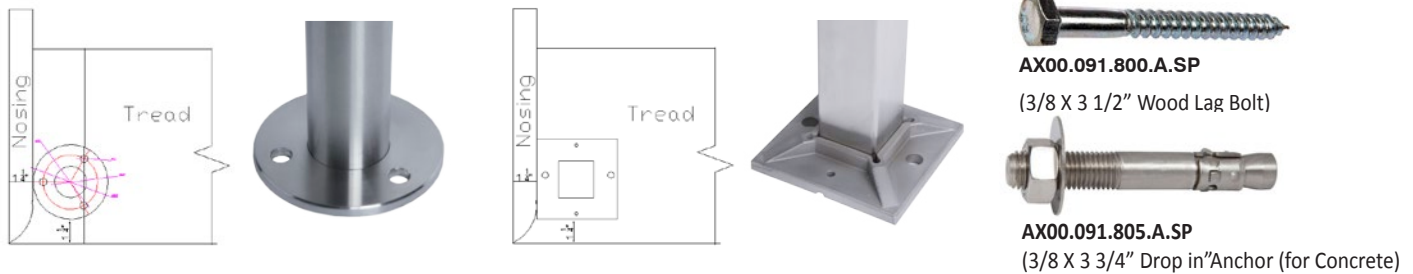

**3. Install all anchor bolts in each hole of newel post.** Three bolts for round and two for square posts. Note; If anchor bolts are penetrating any waterproof deck please follow Waterproofing Co's suggested installation for anchor bolt penetrations. If no manufacturer is available after predrilling for anchor bolt fill hole up with 100% clear silicone sealant and install anchor bolt immediately.

**4. Check newel post for plumb vertically using a 4' Level.** Loosen anchor bolts to allow shims to slip under newel post flange. Install shim(s) to make post plumb. Retighten anchor bolts.



AX00.110.710

**5. Install appropriate rail supports in top of post.** Glue rail supports to posts using "Green" Anaerobic Adhesive. Liberally apply to entire surface of rail support sleeve. Install in post tubing. Remove rail support from tubing and check contact of glue with post. If all sides of post have glue on it then reinstall post rail support in post tube. If glue is not on one side of post apply more adhesive and repeat the process.



AX00.100.525

**6. Clean all excess glue with rag and cleaner immediately.** Use mineral spirits to clean any dry glue off stainless steel. Apply painters tape across the joint from rail support to post tube to prevent joint from spreading during glue drying. Do not remove tape from post and rail support until glue is dry (24 hours).



**AX00.080.515**

INSTALL APPROPRIATE SADDLES IF THEY ARE NOT ALREADY INSTALLED. E.G. FLAT SADDLES FOR FLAT WOOD OR METAL RAIL. CONCAVE SADDLES FOR ROUND RAILING.

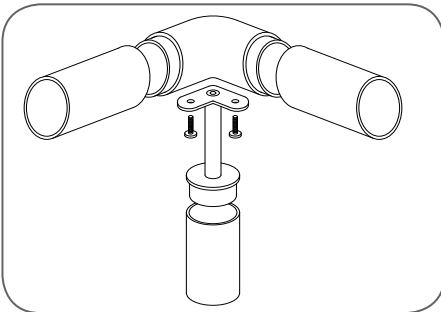

For full instructions on attaching saddles to handrail see the following guide.

**HANDRAIL INSTALLATION**



## Post Railing Systems

### HANDRAIL INSTALLATION

<b>AX10.004.063.3000.A.SP</b>	(1 11/16" x 9'10" Round Tubing)
<b>AX10.004.065.5800.A.SP</b>	(1 11/16" x 19' Round Tubing)
<b>AX20.004.071.3000.A.SP</b>	(1 9/16" Sq. x 9'10" Square Tubing)
<b>AX20.004.070.5800.A.SP</b>	(1 9/16" Sq. x 19' Square Tubing)

### SCREWS

Metal Rail	<b>AX00.091.250.A.SP</b>	(M5 X 12 SS Screws)
Wood Rail	<b>AX00.091.540.A.SP</b>	(M4.8 X 25 SS Wood Screws)

### DRILL BITS & TAPS

5MM TAP= DRILL BIT SIZE 4.3MM =	<b>AX00.070.605</b>
6MM TAP= DRILL BIT SIZE 5.2MM =	<b>AX00.070.606</b>
8MM TAP= DRILL BIT SIZE 6.9MM =	<b>AX00.070.608</b>
5/16"-24 TAP= DRILL BIT SIZE LETTER I	<b>AX00.070.650</b>

### TOOLS REQUIRED

- Cordless or Electric Drill
- Stainless Steel Cutting Saw (Cold Cut Saw, Bench top Portable Bandsaw, Chop Saw with Stainless Steel Cutting Blade)

For more detailed information on tools please visit:  
[www.axiarailing.com/recommended-tools](http://www.axiarailing.com/recommended-tools)

### STEPS REQUIRED

1. Measure and cut desired handrail either metal tubing or wood. When using stainless metal tubing use appropriate rail fittings to make handrail continuous. e.g. 90degree elbow, adjustable angle fitting etc.
2. Where transitioning from stair to balcony / landing and rail height on stairs is 34-38" high and balcony / landing is 42" a gooseneck will need to be installed at the top of the stair section. Using an adjustable angle fitting at the bottom and a 90degree elbow at the top to create the "Gooseneck" (see fig.)

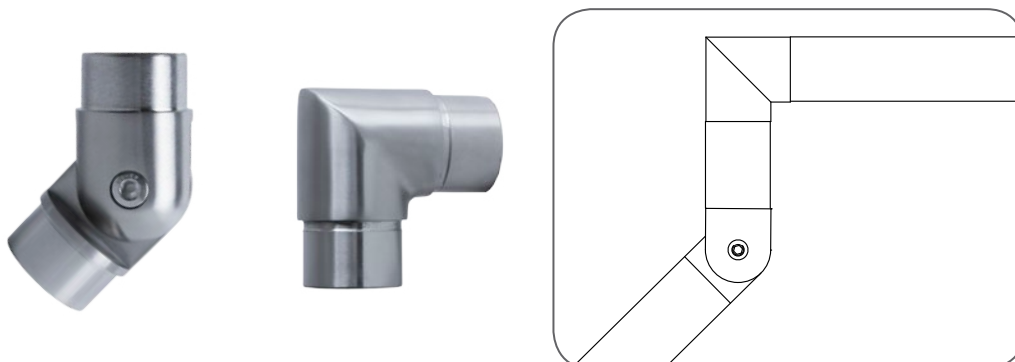

**3. Use Clamps to hold rail sections in place until entire rail is secured.** Be sure to protect tubing from damage from clamps (See fig)

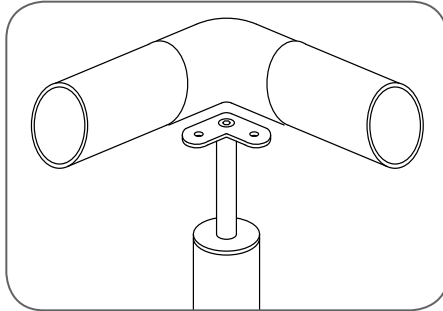

**4. Once the handrail is cut and is in desired configuration and all is straight and level mark holes on bottom of rail at rail support saddles using a fine point sharpie pen.** (see fig.)

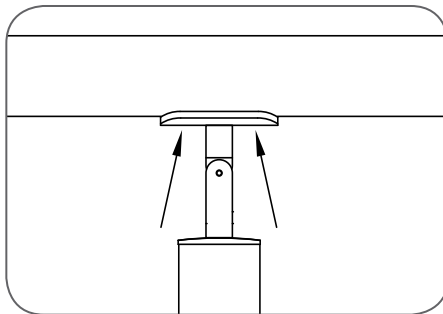

**5. Once all holes are marked, remove handrail from posts and turn over handrail to drill holes with appropriate drill bit (4.3mm bit) for 5mm Tap.** Drill all holes (see drilling holes in stainless) apply three or four drops of cutting fluid before drilling and while drilling holes. (start drilling with 1/8" Drill bit)

**6. Tap hole with 5mm tap. Apply cutting fluid before using tap.** Again, make sure hole is free of any burrs sticking out etc. Repeat for entire handrail sections.

**7. Install handrail by using clamps once again to clamp handrail to post while installing.** Install 5mm screws in rail support saddles, apply thread lock adhesive on screws before installing. Tighten snug but do not overtighten or you could possibly strip out the threads.

**8. Install appropriate rail fittings as you are installing the handrail sections.** Using "witness" mark across edge of fitting and tubing with Sharpie marker to install fitting in appropriate orientation. Apply anaerobic adhesive on fitting section that goes inside the tube liberally and install fitting. Be sure to realign "witness" mark and tape with blue painter's tape across joint until dry.

**9. Install appropriate Wall Mount Flange where rail terminates into wall using flange and screws.** Apply two large dollops of clear silicone on top of flange to secure flange cover to flange to keep tight to wall.

**8. Install appropriate rail fittings as you are installing the handrail sections.** Using “witness” mark across edge of fitting and tubing with Sharpie marker to install fitting in appropriate orientation. Apply anaerobic adhesive on fitting section that goes inside the tube liberally and install fitting. Be sure to realign “witness” mark and tape with blue painter’s tape across joint until dry.



**9. Install appropriate Wall Mount Flange where rail terminates into wall using flange and screws.** Apply two large dollops of clear silicone on top of flange to secure flange cover to flange to keep tight to wall.

Wall mount flange



Adjustable wall mount flange



Flange Cover



## Post Railing Systems - Infill

### SWAGED CABLE INSTALLATION

AX00.050.221SX.B.SP	(Left handed cable terminal stud (SX)
AX00.050.220DX.B.SP	(Right handed cable terminal stud (DX)
AX00.050.231SX.B.SP	(Left handed threaded nut cap tensioner (SX)
AX00.050.230DX.B.SP	(Right handed threaded nut cap tensioner (DX)
AX00.050.233SX.B.SP	(Left handed Allen head cap tensioner (SX)
AX00.050.231DX.B.SP	(Right handed Allen head cap tensioner (DX)
AX10.060.245.B.SP	(Sloping washer for round posts)
AX20.060.245.B.SP	(Sloping washer for square posts)
AX00.050.235.B.SP	(Middle tensioning body)
AX00.040.215.B.M	(1x19 strand - 4mm cable(316 grade) 328' spool



### TOOLS REQUIRED

- String or chalk line
- 5.3 mm drill bit
- #2 Philips bit
- Magnetic bit holder
- 1/8" Cobalt bit
- Tape Measure
- Cordless or electric drill
- Cable Cutter
- Stainless Steel cutting saw (Cold Cut Saw, Bench top Portable Bandsaw, Chop Saw with Stainless Steel Cutting Blade)

For more detailed information on tools please visit:  
[www.axiarailing.com/recommended-tools](http://www.axiarailing.com/recommended-tools)

### STEPS REQUIRED

1. Using a  $\frac{1}{2}$  x  $\frac{3}{4}$  or other piece of scrap trim cut to length of newel posts for "Layout Stick"

2. Clamp trim to end of bottom newel post.

3. Using long straight edge, level, trim etc. Place on nosing of stairs and mark across side of newel post the angle alongside of newel.

4. Place "Layout Stick" bottom on the line at the face of the newel post the "layout stick" is on.

5. Measure and mark with tape measure spacing for cable holes measuring up the stick. Remember that spacing should be measured perpendicular to rail or long straight edge and not vertically up the newel post.

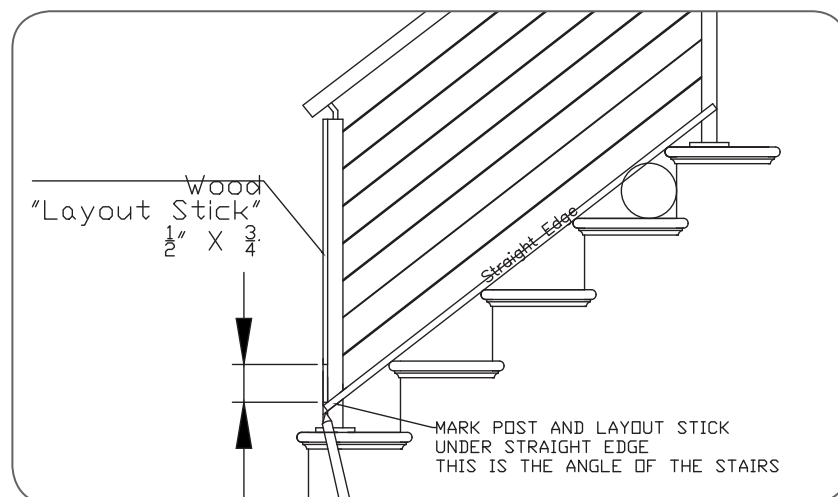

Once you have one space measured perpendicular you can measure the vertical space on the “Layout Stick” and repeat the span. Note: this measurement varies depending on the angle of your staircase so if your rise and run are different on separate section of stairs then you will need to repeat these steps to find the spacing measurement. Note: The bottom cable on an open tread staircase should not be more than 1/2” of an inch above the nosing of the treads in order to meet the 6” sphere code in the triangle section created by the tread and riser at the side of the stairs.

- a. We recommend 3 1/4” spacing between cable to allow for stretching of cable and still pass the 4” sphere code during inspection. 3 1/16” spacing or 3 3/16” center to center measured perpendicular to handrailing. For example; with a 10” run and 7 3/4” rise the spacing for 36” railing is 3 1/16” or 3 3/16” center to center. Vertically that measures 4 1/16” vertically up the post.

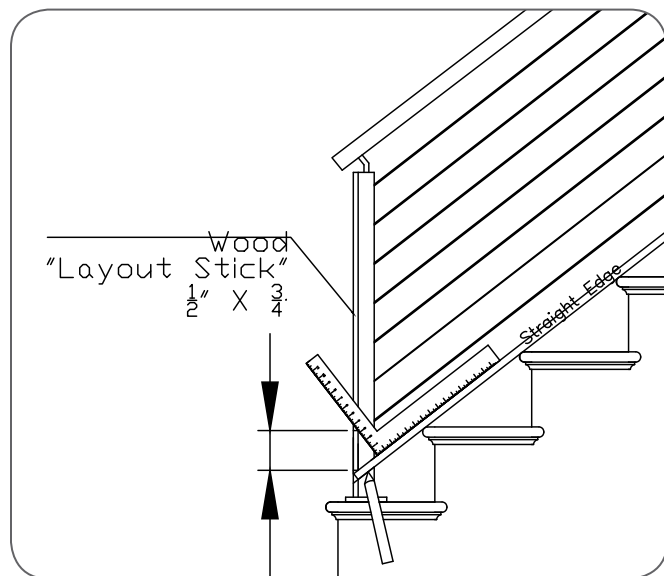
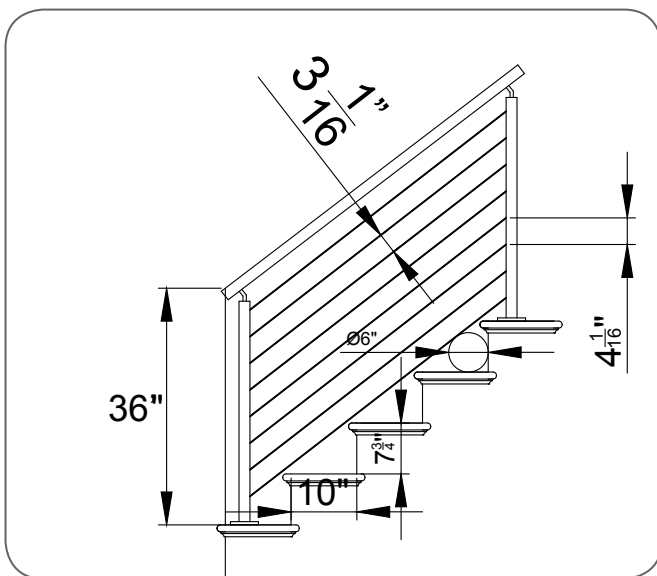

**6. Once “Layout Stick” is marked with all locations of cable. Start with an 1/8” Cobalt drill bit and drill wood “Layout Stick” on marks on work bench (not on newel post) once all 1/8” Holes are drilled in “Layout stick” place back on newel post and clamp to post. Be sure to line up bottom angle mark to bottom of layout stick when moving to backside of post.**

Drill 1/8” holes in holes on “Layout Stick” into metal newel post. Use 3 or 4 drops of cutting fluid on drill bit as you are drilling holes. Keep drill bit level and parallel with railing while drilling holes. Once all holes are drilled on “Layout Stick” Move to backside of Newel post. Line up angle mark on the side of the post with the bottom of the “Layout Stick” and clamp to newel post. Drill holes in newel post on Layout stick with 1/8” Cobalt drill bit using 3 or 4 drops of cutting fluid on each hole.

**7. Once all holes are drilled with 1/8” drill bit re-drill holes with 5/16” Cobalt drill bit (crimp style fittings) on stairs using 1/8” pilot hole as a guide and drill 5/16” hole on each side straight in.** Once holes are drilled straight, push 5/16” bit through newel and locate hole on the opposite side of newel post and put point through the hole and drill on the angle of the staircase. Be sure to drill from both directions to clean out and burrs left from drilling. Use cutting fluid on drill bit while drilling to prevent burning and burring. Tip: Be careful that drill chuck does not mar the surface of the stainless newel post while drilling holes.



**8. Cable cutting - To measure for the correct cable lengths measure between the newel posts and rough-cut cable pieces needed for each section.** Eight rows for stairs with 36" high rail and 11 rows for balcony @ 42" high rail. Once cable is rough cut for each section, crimp the LH (SX) cable terminal stud on one end of each cable.



Cable cutter  
HFC18.CUTTER



Hydraulic Crimper  
AX00.060.400

**9. Once all cables have cable terminal stud on one end, install terminal stud into bottom hole of newel post on the left hand side of section of handrail.** Install LH nut cap tensioner or Allen head cap tensioner on end of terminal on outside of newel post. Tighten threads only 2 to 3 full turns.

**10. Install RH (DX) Terminal stud into hole on opposite end of railing section and install nut cap tensioner or allen head cap tensioner on end of terminal on the outside of the newel post.**

If on stairs, use the sloping washer along with the nut cap tensioner. Tighten on 2 to 3 turns. Note: Be consistent with the amount of turns you use for all fittings to keep fitting ends lined up when all cable is installed and tightened.

**11. Pull cable from crimped fitting end and pull towards uncrimped fitting and lay beside cable terminal fitting and hold, mark the length to fitting and add 1-1/8" and cut the cable to length.**

**12. Crimp fitting on cut cable end and install into newel post hole and tighten on the end nut cap tensioner or Allen head tensioner until cable is hand tight and taught.**

DO NOT TIGHTEN CABLE MORE THAN HAND TIGHT AT THIS TIME. Repeat this process moving up each section until all cable are installed hand tight and taught.

**13. After all sections of cable are installed and hand tight be sure that all glue on handrail supports is fully cured (24 to 48 hours) before tightening cable.** Tip: In Cold weather conditions Anaerobic adhesive cure time is longer. To speed up the curing, use a heat gun to warm up the post rail support.

**14. Be sure all handrail screws on saddles to handrail are tight before tightening cable.**



**15. Once all screws and glue are dry you can proceed to tighten cables.**

Note: it is better to wait at least 24 hours (overnight) with cable hand tight (taught) to relax the cable before tightening. This will help reduce call backs for cable sagging after installation.

**16. To tighten cable start with the middle row of cable and tighten using socket or Allen wrench on nut cap or Allen head tensioner on each end of cable.** Check tension on each cable as you are tightening with cable tension gauge. Apply 225lbs of tension on each cable. Do not over tighten (see fig.)

**17. Tighten row above middle then row below middle and keep alternating as you are tightening cables.** Note: Be sure to check tension with tension gauge on each cable as you are going and do not over tighten cable.

**18. Once each section is complete recheck tension on each cable and tighten as needed, starting in the middle row and working out again.**

**19. Tighten all sections except one and leave taught. It is ideal to now teach your homeowner or customer how to tighten cable and clean cable periodically. Using same methods as originally installed.**

This will prevent future call backs for loose cable and inform your client that tightening, and cleaning of the cable and cleaning stainless posts and rail is a maintenance item and manufacturer recommendations should be followed to avoid issues.

**20. Leave all degreaser, cleaner and passivator for stainless rail and cable to be cleaned and protected (if exterior) periodically typically once a month or so. Depending on location, weather, pollution etc.**

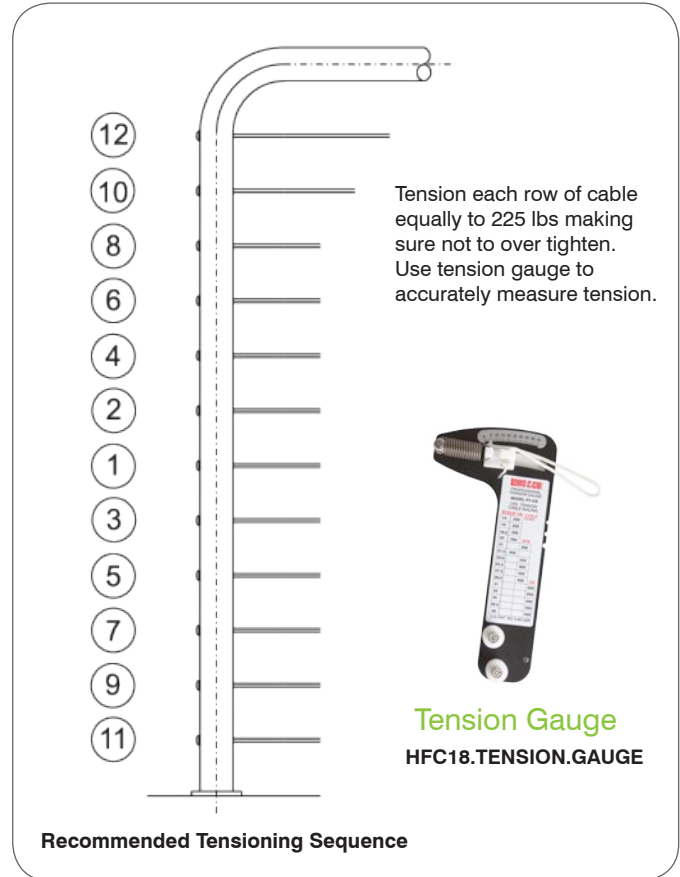

Step 1

**Degreaser**

AX00.080.515



Step 2

**Cleaner/Polish**

AX00.080.510



Step 3 (required for exterior)

**Polish/Passivator**

AX00.080.517

# Ultra-Flex Installation Instructions

## Swageless Tensioning Fittings



A. Wood Level Tensioner



B. Wood Stair Tensioner



C. Metal Level Tensioner



D. Metal Stair Tensioner

### A: Drill Posts

1. Make sure the holes are drilled properly in the end post where you will be installing the fitting.  
***If you are using wood end posts***, drill a hole into your wood posts a least 1½" deep at 7/32".

#### Hole size for 1/8" dia. cable installation:

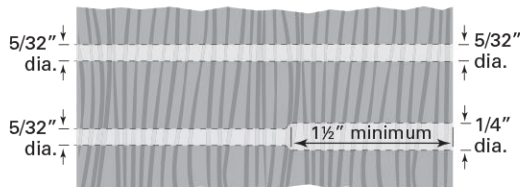

For Intermediate Post  
passing cable only

For Intermediate Post  
passing cable  
through CS Tube side

#### Hole size for 3/16" dia. cable installation:

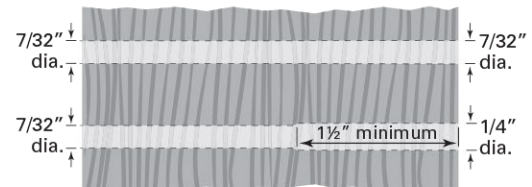

#### Hole size into end posts:

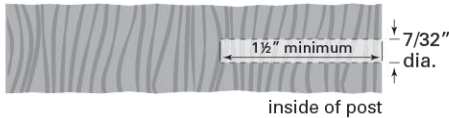

inside of post

***If you are installing the fittings in a metal railing***, drill and tap your end posts to 5/16-24.

#### Hole sizes through intermediate posts and/or cable braces are:

- 5/32" for 1/8" cable
- 7/32" for 3/16" cable

#### End posts:

Drill and tap 5/16-24 threaded holes on the inside of each end post.

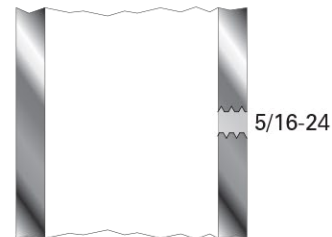

## B. Install Tensioning Terminal

- 1A.** If you are using the Wood Level Tensioner, place lag thread into pre-drilled hole and drive lag thread into wood post (or wood post with composite sleeve with a diameter up to 4½") using a 3/16" hex (Allen) wrench. Stop turning when the lag threads on the fitting are fully within the wood post. Assemble female threaded rotating portion of fitting onto male thread only so far as to cover male thread and no more.

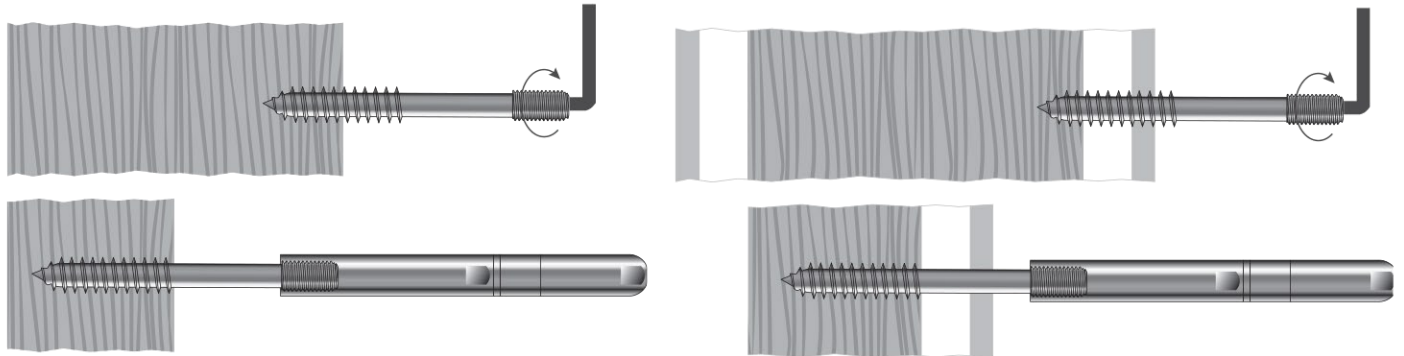

- 1B.** If you are using the Wood Stair Tensioner, place lag thread into pre-drilled hole and drive lag thread into wood post using the articulating portion of the fitting as a lever to rotate the lag end of fitting. Stop turning when shoulder on fitting between lag thread and clevis makes contact with wood post face. You may continue to rotate fitting up to 1/4 turn to properly orient the fitting. If the wood is too hard to rotate 1/4 turn clockwise, it may be backed off 1/4 turn to achieve proper orientation. Assemble female threaded rotating portion of fitting onto male thread only so far as to cover male thread and no more.

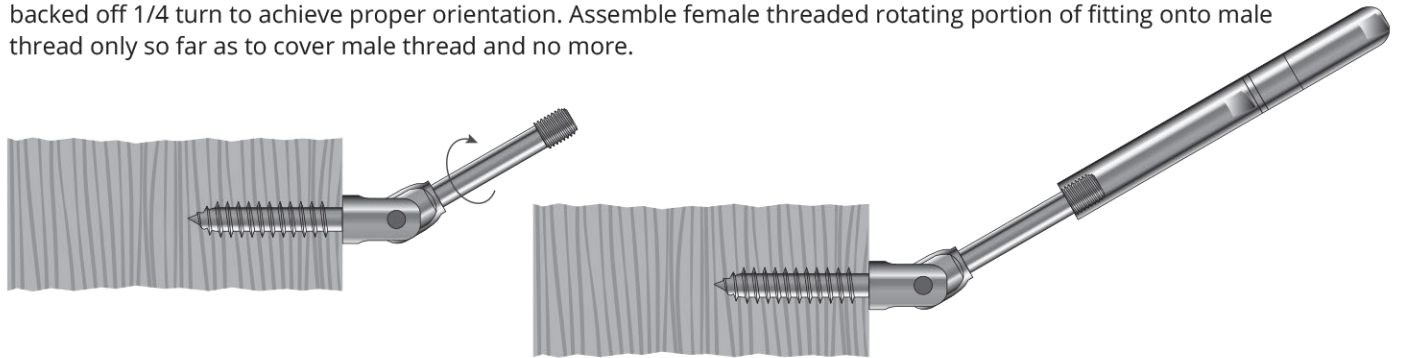

- 1C.** If you are using the Metal Level Tensioner, hand turn the threaded bolt component of the assembly clockwise into the post, tightening with a 3/16" hex wrench. Assemble female threaded rotating portion of fitting onto male thread only so far as to cover the male thread and no more.



- 1D.** If you are using the Metal Stair Tensioner, hand turn the threaded clevis into the post using the articulating portion of the fitting as a lever to rotate the part. Tighten such that the unattached arm hangs vertically. Assemble female threaded rotating portion of fitting onto male thread only so far as to cover the male thread and no more.

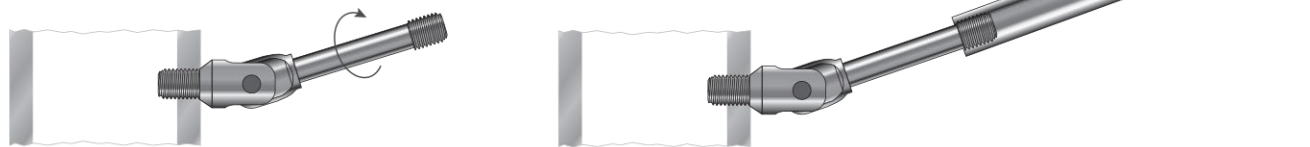

- 2.** Go to the other end of the cable run and install the non-tensioning fitting.



# Push-Lock Stop-End (non-tensioning) Fittings

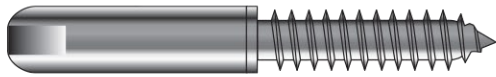

A. Wood Level Non-Tensioner



C. Metal Level Non-Tensioner



B. Wood Stair Non-Tensioner

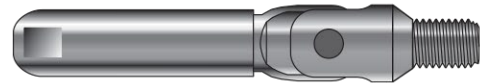

D. Metal Stair Non-Tensioner

## C: Drill Posts

1. Make sure the holes are drilled properly in the end post where you will be installing the Push-Lock fitting. See Section A for detailed instructions.

## D. Install Non-Tensioning Terminal

- 1A. If you are using the Wood Level Non-Tensioner, place lag thread into pre-drilled hole and drive lag thread into wood post using our DRIVER PL-LAG tool (or a 3/8" open-end wrench) on wrench flats milled into body of fitting. Stop turning when shoulder on fitting between lag thread and body makes contact with wood post.

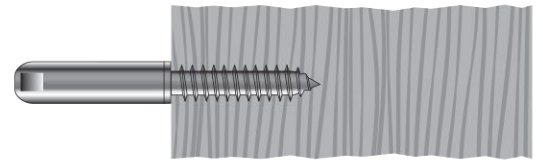

- 1B. If you are using a Wood Stair Non-Tensioner, place lag thread into the pre-drilled hole and drive lag thread into wood post using the articulating portion of the fitting as a lever to rotate the lag end of fitting. Stop turning when shoulder on fitting between lag thread and clevis makes contact with the wood post face. You may continue to rotate fitting up to 1/4 turn to properly orient the fitting. If the wood is too hard to rotate 1/4 turn clockwise, it may be backed off 1/4 turn to achieve proper orientation.

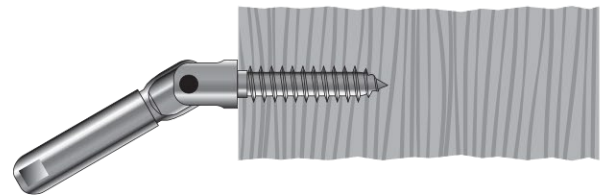

- 1C. If you are using the Metal Level Non-Tensioner, place a black Delrin® washer over the threaded bolt. Turn the fitting into the pre-drilled and tapped 5/16-24 hole in the post using our 3" Combo Wrench tool (or 3/8" open-end wrench) on wrench flats milled into body of fitting. Stop turning when shoulder on fitting between threaded bolt and body makes contact with metal post.

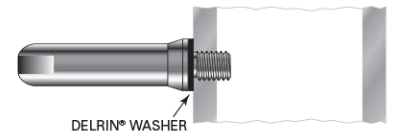

- 1D. If you are using a Metal Stair Non-Tensioner, hand turn the fitting into the pre-drilled and tapped 5/16-24 hole in the post using the articulating portion of the fitting as a lever to rotate the threaded end of fitting. Stop turning when shoulder on fitting between the thread and clevis makes contact with the metal post face. You may continue to rotate fitting up to 1/4 turn to properly orient the fitting.

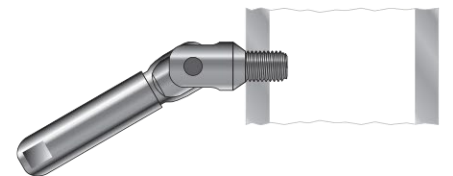

2. Pull the cable tight and mark the cable at a point 1-3/16" from the end of the fitting away from the post. Cut the cable at the mark, using a cable cutter.

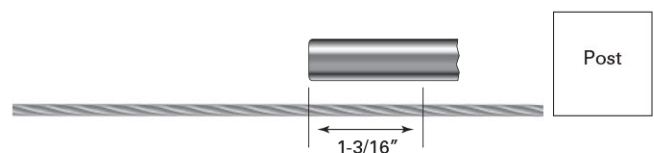



3. Push the cable into the hole in the fitting as far as it will go (approximately 1-1/16"). Twist the cable clockwise as you push it into the fitting. You will feel it slide through the jaws inside the fitting. FULL INSERTION OF THE CABLE IS CRITICAL TO FITTING PERFORMANCE UNDER TENSION.

(If applicable, you will receive a PL-Key with your order. This may aid in your cable installation. Please see instructions for use of the PL-Key at the end of this section).

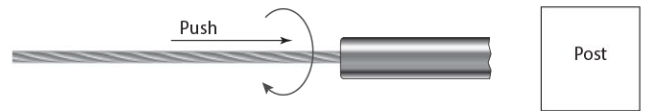

*Note: If you have trouble inserting the cable into the fitting, it may be because the locking wedges have become stuck. This is not a defect! Here's what you can do to "free the wedges" — For fittings for 1/8" cable, using a 1/4" diameter bolt, insert the bolt into the hole and press until the wedges move freely. Perform the same operation for a 3/16" fitting, except use a 16d nail or another tool with 1/8" or smaller diameter. Anything larger than what is recommended can actually get stuck inside the fitting – NOT what you want!*

## E. Tension Cables

1. Feed bare end of cable through intermediate posts and repeat same steps to insert cable into pre-attached swageless tensioning fittings as non-tensioning fittings.

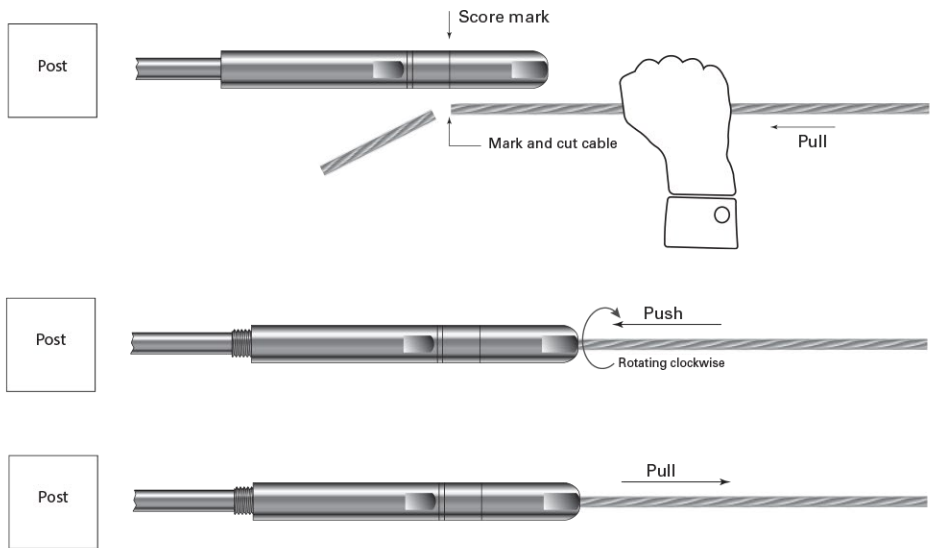

2. After successfully attaching the non-tensioning fitting, tension cable by holding tensioner body at 3/8" wrench flat nearest cable (do not let this section rotate while cable is inserted) and rotating female threaded section of fitting with a 3/8" open-end wrench onto threads.

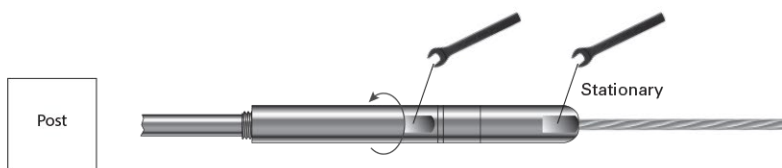

3. Tension all cables in sequence, beginning with the center cables, moving up and down toward the top and bottom. As you tension each cable, give it a sharp pull downward mid-span to help set the wedges, then re-tension as necessary in the same sequence. Be aware that the cable may move as much as 3/16" as the wedges seat.

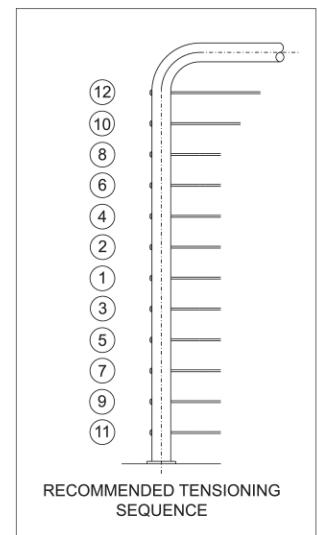

## Post Railing Systems - Infill

### HORIZONTAL ROUND BAR INSTALLATION

AX10.009.83000.A.SP	(12 x 1.5 mm 3000 mm 1/2" Tubing)
AX10.009.85800.A.SP	(12 x 1.5 mm 5800 mm 1/2" Tubing)
AX10.010.200.A.SP	(Bar holder for round posts)
AX10.010.205.A.SP	(Bar holder for square posts)
AX10.010.206.A.SP	(Holder for splice in bar (2 set screws))
AX10.010.082.A.SP	(Inline adjustable angle connector)
AX10.010.209.A.SP	(Inline holder for mounting to wall or ceiling)
AX10.010.081.A.SP	(End caps)
AX10.010.208.A.SP	(Cross holder for vertical Bars)

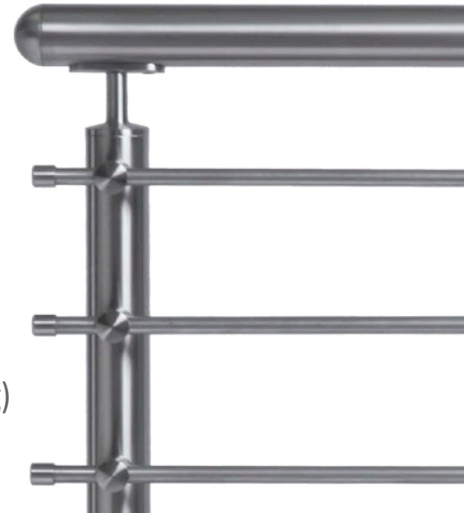

### TOOLS REQUIRED

- String or chalk line
- 5.3 mm drill bit
- 6 mm tap
- #2 Philips bit
- Magnetic bit holder
- 1/8" Cobalt bit
- Tape Measure
- Cordless or electric drill
- Stainless Steel Cutting Saw (Cold Cut Saw, Bench top Portable Bandsaw, Chop Saw with Stainless Steel Cutting Blade)

For more detailed information on tools please visit:  
[www.axiarailing.com/recommended-tools](http://www.axiarailing.com/recommended-tools)

### STEPS REQUIRED

1. Use Sharpie to mark under straight edge on side of newel post layout trim (see fig.)

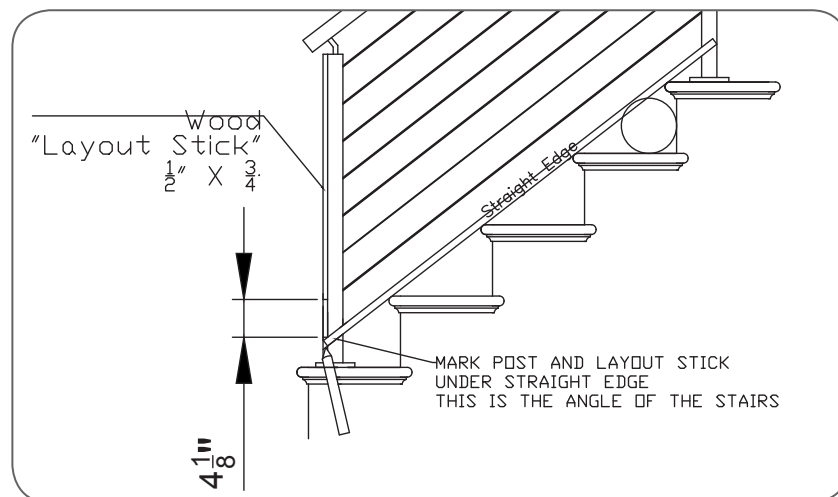

2. Layout spacing for bar from mark note the bottom horizontal bar should not be more than approximately 3/4" above nosing on a typical staircase or triangle section on open treads will be more than the 6" Sphere allowed by code. See IRC Code R312.3 Guard Opening Limitations. Required guards shall not have openings from the walking surface to the required guard height which allow passage of a sphere 4 inches (102 mm) in diameter. Exceptions: 1. The triangular openings at the open side of a stair, formed by the riser, tread and bottom rail of a guard, shall not allow passage of a sphere 6 inches (153 mm) in diameter. 2. Guards on the open sides of stairs shall not have openings which allow passage of a sphere 4 3/8 inches (111 mm) in diameter.

**3. Layout horizontal bar so that they are a maximum  $3 \frac{15}{16}$ " Apart to meet Code. We Recommend  $3 \frac{1}{4}$ " apart to allow for flexing of the bar and still pass inspection.** Note: On stairs do not measure spacing up the post vertically. The spacing should be measured perpendicular to the handrail angle. The vertical measurement varies depending on the angle of your stairs.

**4. Place straight edge or piece of trim on nosing of stairs and measure from the bottom of the straight edge to the bottom of first horizontal bar holding tape measure perpendicular to straight edge.**

You can also use a small framing square (see fig.)

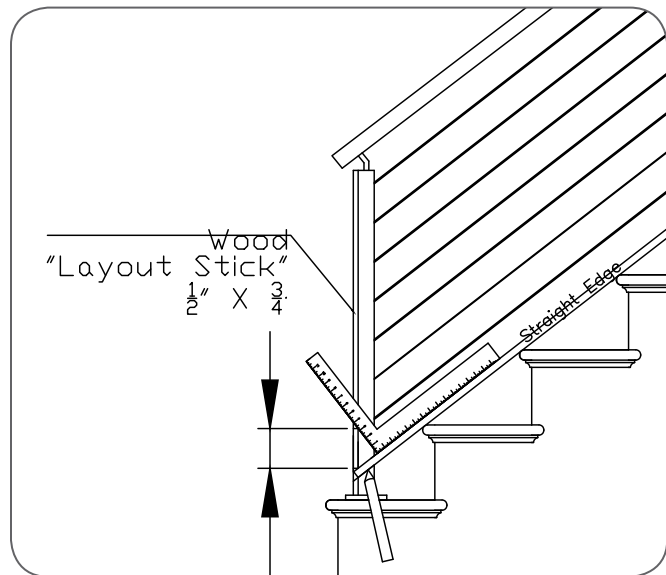
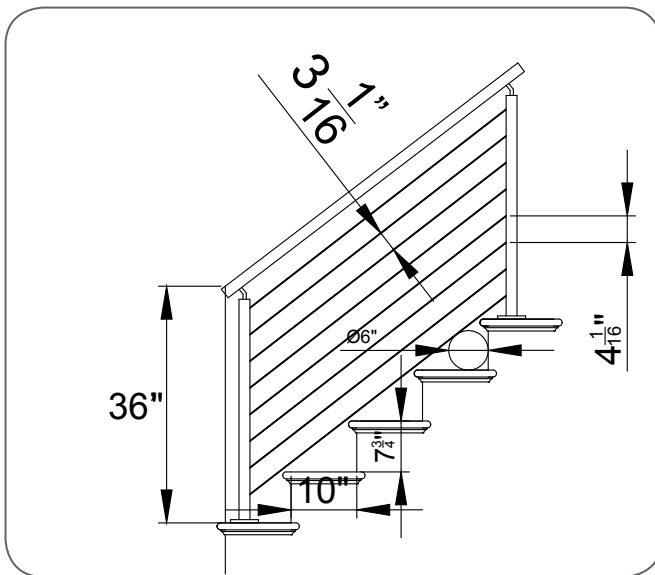

**5. After marking bottom hole on bottom and top newel post only, run a string line or chalk line from post to post from each mark. Pull string tight so it is straight and tape or clamp to end posts.**

**6. Mark Intermediate posts where string crosses center of newel posts.**

**7. Clamp long straight edge to newel post on 1st bar mark on end post and intermediate posts make sure it's on the line on all posts.**

**8. Measure from straight edge to second bar holder location perpendicular to straight edge using tape measure or square. Mark all posts including intermediate.**

**9. Remove straight edge.**

**10. Measure distance on bottom post between bottom bar holder mark and 2nd bar holder mark.**

This is the measurement to repeat spacing vertically up the post for remaining bar holder locations. Mark top and bottom post only or end posts and use string or chalk line stretched tight to mark intermediate bar holder locations on each row. This will ensure each bar is straight when completed.

- 11. When all bar holder locations are marked use 3/8" or 1/2" center punch and make a firm tap at each bar holder location.** A slight indentation should be created.
- 12. Using an electric or cordless drill, drill pilot holes with 1/8" cobalt drill bit at each mark on the newel post.** Be sure to use 2 to 3 drops of cutting fluid on bit for each hole as drilling.
- 13. Next, switch to a 5.2mm drill bit and drill all holes again.** Be sure to use a couple of drops of cutting fluid in each hole to keep the bit from burning the Stainless, this will also ensure the drill bit will last longer.
- 14. Once all holes are drilled with 5.2mm bit make sure there are no metal burrs sticking out of metal post.** Use drill bit to clean burrs by sticking bit back into hole and running in and out of hole several times.
- 15. Install 6mm Tap into Drill Chuck of drill.** Adjust drill to slowest speed gear or if variable speed, keep RPM'S low, push tap into hole. Be sure to apply a few drops of cutting fluid while tapping each hole. Be sure drill is in forward gear. Be sure tap is level and square as you are tapping. Stop drill before drill chuck hits newel post, put drill in reverse and back the tap out slowly. Repeat several times to be sure threads are clear of any burrs.
- 16. After all holes are tapped, clean any oil/grease from the newel post with degreaser.** Remove blue tape from newel posts and install bar holder at each location.

- 17. Install bar Holder, remove back section of bar holder by loosening the set screw with an Allen wrench.**



AX10.010.200.A.SP

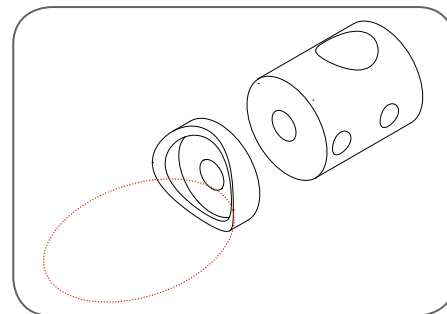

- 18. Remove back section of holder and place on newel post over each drilled and tapped hole.**
- 19. Install 6mm Screw provided to hold back section in place.** Be sure to apply Thread Lock adhesive on screw threads as you are installing screw. Tighten snug but do not over tighten.
- 20. Install outer section of bar holder onto back section and tighten so bar holder does not fall off but still can be twisted and stays at any angle.**
- 21. After all bar holders are installed, measure, cut and install horizontal bar tubing or bar to desired length.** Allow for overhang at each end to allow for end caps on each bar past the end post bar holders (see fig.)



**22. Once all Bars are cut, install one bar sliding through bar holders and tightening outer set screw to secure bar in holder.** Be sure to tighten inner set screw on each bar holder as you are installing each bar as to not miss any set screws.

**23. Install end caps and or adjustable fittings on bar ends and transitions as you are installing using anaerobic adhesive in inside of end cap and apply to bar. Clean any excess glue immediately.** Tape end cap to bar until glue dries (allow 24 to 48 hours for glue to fully cure).

**24. After all bars are installed and glue is dry, clean all bars, posts and railing using degreaser, Use Scotch Brite pad to remove any small scratches by sanding with pad with the grain of stainless.**



AX00.080.505



Step 1

Degreaser

AX00.080.515



Step 2

Cleaner/Polish

AX00.080.510

**25. Reclean all stainless rail with cleaner polish.**

**26. Tap or bang on rail with closed fist to check for rattles (loose screws).** If rattle is detected, locate the rattle (loose screw) and tighten.

**27. Remove all fingerprints and clean for final inspection.**

**28. For exterior applications, apply passivator fluid using cloth rag and wipe onto stainless railing, posts, etc.**



Step 3 (required for exterior)

Polish/Passivator

AX00.080.517

## Post Railing Systems - Infill

### GLASS CLAMPS INSTALLATION

AX10.014.180.A.SP	(Glass clamps for round posts)
AX10.015.182.R	(Rubber insert fo round clamp, 3/8" glass)
AX10.015.183.R	(Rubber insert fo round clamp, 1/2" glass)
AX20.014.190.A.SP	(Glass clamps for square posts)
AX10.014.191.R	(Rubber insert fo square clamp, 3/8" glass)
AX10.014.192.R	(Rubber insert fo square clamp, 1/2" glass)



### TOOLS REQUIRED

- String
- 1/8" Cobalt bit
- 6.9 mm Cobalt bit
- 8 mm tap
- Thread Lock
- Tape Measure
- Magnetic bit holder
- Cordless or electric drill
- Cutting fluid
- Stainless Steel cutting saw (Cold Cut Saw, Bench top Portable Bandsaw, Chop Saw with Stainless Steel Cutting Blade)

For more detailed information on tools please visit:

[www.axiarailing.com/recommended-tools](http://www.axiarailing.com/recommended-tools)

### STEPS REQUIRED

1. Mark location of glass clamps on inside of newel post according to diagram provided, or desired location.

2. Glass clamps can be installed using Bottom "swift plate" to allow glass to rest on. Safety pins are not required in panel to avoid glass from falling out of clamps. Or you can use safety pins on glass clamps in lieu of swift plate.

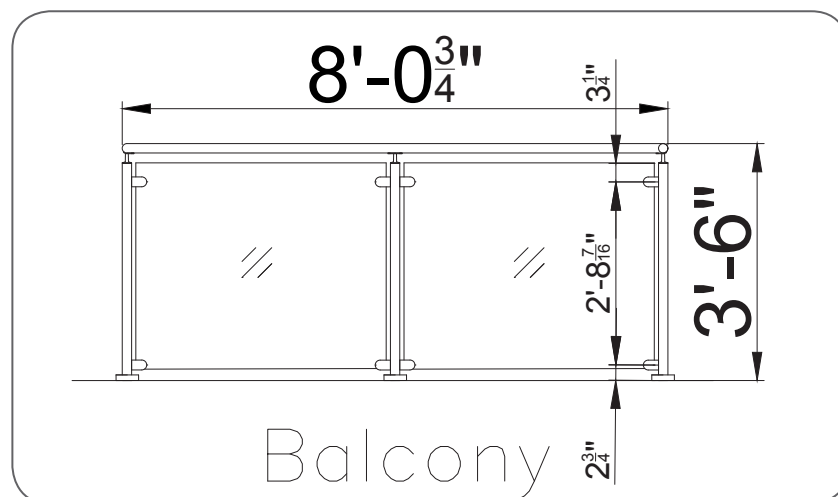

3. Drill an 1/8" pilot hole using a Cobalt Drill bit at the center of each glass clamp. Use 3 or 4 drops of cutting fluid to keep bit from burning, repeat as necessary. Drill final hole with 6.9 mm Cobalt Drill bit for glass clamp. Install tap in drill and "drill" with tap into hole to cut 8mm threads into hole. Use slow RPM's and 3 or 4 drops of cutting fluid. Once tap is 3/4 into post stop and reverse drill and "back out" the tap out of the post. Clean debris and oil with rag. Install 8mm screw into threads to "clean out threads", install glass clamp by removing the two screws on clamp and separating the two halves of the clamp.



**Once you have one space measured perpendicular you can measure the vertical space on the “layout stick” and repeat the span.** Note: this measurement varies depending on the angle of your staircase so if your rise and run are different on separate section of stairs then you will need to repeat these steps to find the spacing measurement. Note: The bottom cable on an open tread staircase should not be more than 1/2” of an inch above the nosing of the treads in order to meet the 6” sphere code in the triangle section created by the tread and riser at the side of the stairs.

a. We recommend 3 ¼” spacing between cable to allow for stretching of cable and still pass the 4” sphere code during inspection. 3 1/16” spacing or 3 3/16” center to center measured perpendicular to handrailing. For example; with a 10” run and 7 ¾” rise the spacing for 36” railing is 3 1/16” or 3 3/16” center to center. Vertically that measures 4 1/16” vertically up the post.

**4. Install outer half of Glass Clamp with 8mm Screw and tighten. Be sure clamp is centered in Newel.** Be sure to use Thread Lock (Blue Label Glue) to avoid screws from backing out from vibration.

**5. Be sure glass clamps are on the same plane as each other.**

Tip: to check glass clamp plane alignment, take string and cross from top clamp left to bottom clamp right and from top clamp right to bottom clamp left. Strings should touch in the middle. If strings are not touching adjust clamps until strings touch in the middle of the X. See fig

**6. Cut Plywood Template for Glass using 3/8 or ½” plywood (BC or Sanded Plywood) Allow 1/8 gap between template and glass clamp on each side.** Cut template to height of Newel posts. Be sure to install template with the rubber pads installed in clamp and tighten clamp completely. Check all measurements (Margins) around glass are equal, straight. Scribe to newel post, or rail if necessary, to keep equal margin. Once all margins are correct leave all templates on project in place until entire project is complete.

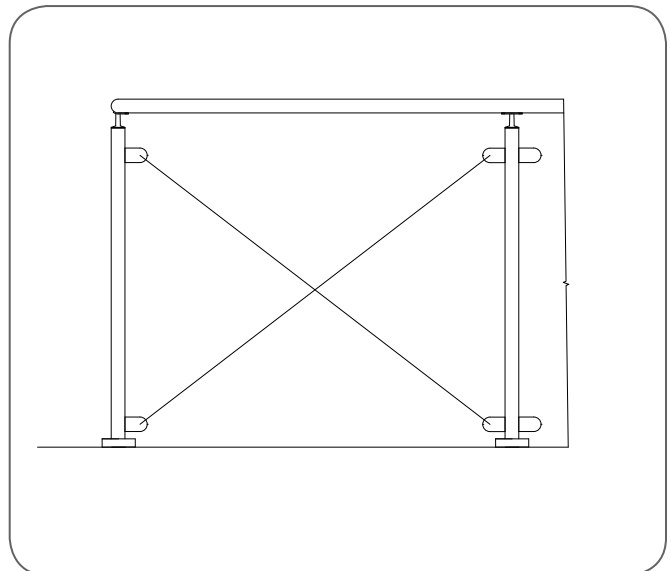

**7. Once all templates are cut and installed mark or number each template 1 of total #, 2 of total #, Etc. E.G. 1 of 15, 2 of 15, 3 of 15 etc.** Label on templates, job name and address phone number etc. Desired glass, edge treatment, e.g. flat polished edges, Bumped corners etc. Example: 3/8” Clear Tempered, Flat polished edges, Bumped Corners. Be sure to drill any holes on the template for safety pins. Drill ½” hole for safety pin.

**8. Once all templates are cut, installed and labeled.** If desired make second set of templates for safety panels to be in place during construction while you are waiting for glass to be made and delivered.

**9. Tie all glass templates together with string and take to a glass supplier to have glass made same as templates provided.** Be sure to remove the rubber pads and store in a box and set in safe location until glass is ready to install to keep from losing the pads.

10. Once glass is ready to install, remove glass clamp inner halves and install glass panels. Be sure to get help holding the glass while you are tightening the glass clamps. This is a two-person job. One person holds the glass while the other installs and tightens inner half of glass clamp.
11. Install pads on outer half of glass clamps on panel you are working on only.
12. Set glass panel into glass clamps either on swift plates at bottom (balcony) cut scrap block of wood to support glass on stairs (rake) and install safety pins in hole in glass and align with hole in outer half of glass clamp.
13. Install inner half of glass clamp ensuring swift plate or safety pin are aligned and seated in inner half of clamp as you are pushing together and tighten screws.
14. Check margins around glass to post and rail to make equal. Loosen clamps and adjust glass as necessary to make margins equal or even.
15. Tighten all screws in glass clamps.
16. Clean glass and stainless steel of all fingerprints and remove labels etc.
17. **Note: Tempered glass is required for all stairs and balcony railing as this is considered a hazardous location, see. IRC 2406.4.4 Glazing in Guards and Rails, Including Structural Baluster Panels, and Nonstructural Infill Panels, regardless of area or height above walking surface, shall be considered to be a hazardous location.**
18. **Handling Tempered Glass; be sure to use gloves when handling glass.** The edges of Tempered glass are the most fragile and if tapped or hit lightly can shatter the entire piece of glass. When delivering glass set pieces vertically against wall and set on 2 scrap strips of wood to keep glass off floor to avoid entire bottom edge from having contact with floor, debris etc. Glass suction cup lifters are ideal to help move heavy glass pieces.

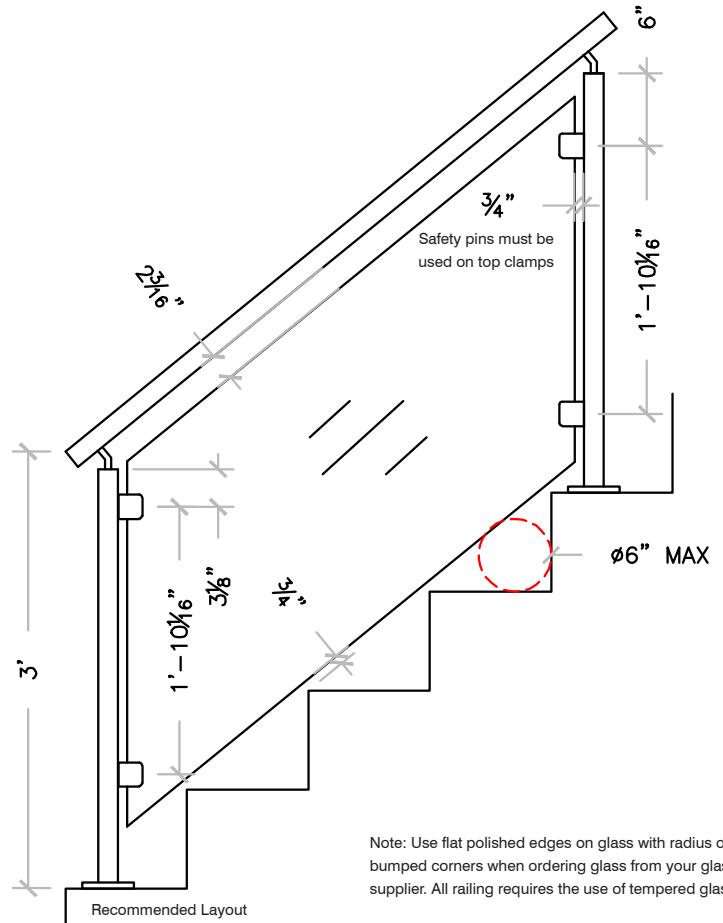
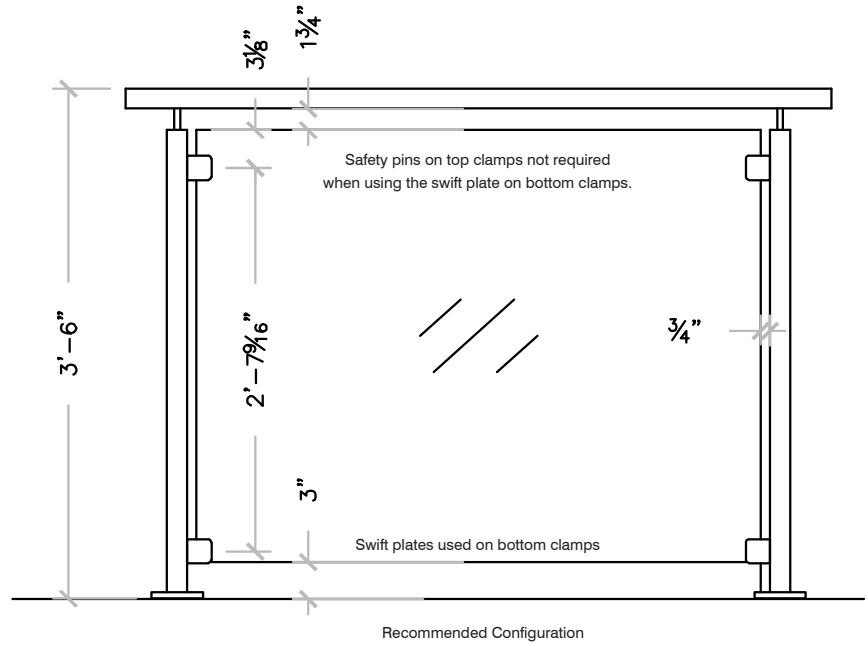
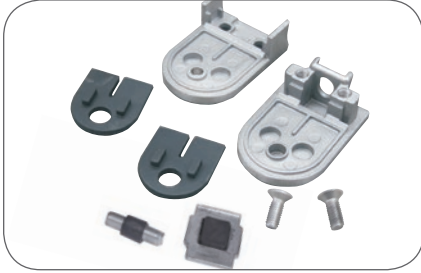

Note: Use flat polished edges on glass with radius or bumped corners when ordering glass from your glass supplier. All railing requires the use of tempered glass.

## Glass Railing Systems

### GLASS STANDOFF INSTALLATION

AX30.017.040.A.SP	(Round glass standoff)
AX30.017.042.F	(Leveling shim for round standoff)
AX30.017.041.A.SP	(Square glass standoff)
AX30.017.043.F	(Leveling shim for square standoff)



### TOOLS REQUIRED

- Spanner Wrench - round (AX30.070.530)
- Spanner Wrench - square (AX30.070.531)
- Circular Saw
- Tape Measure
- Magnetic bit holder
- Cordless or electric drill
- Cutting fluid

For more detailed information on tools please visit:  
[www.axiarailing.com/recommended-tools](http://www.axiarailing.com/recommended-tools)

### STEPS REQUIRED

#### 1. Layout wall for recommended Layout of Standoff Clamps for Balcony or Stair application.

We recommend 18" from floor to the bottom of the glass if possible. With 3 inches up and 3 inches down to center of clamp and 3 inches from each side for center. This will give you 12" from center to center vertically. Minimum recommend vertical dimension from center to center of each clamp is 7 ½" Inches. Maximum recommended width of glass panel is 4' with a minimum of 4 Stand-off clamps per panel. Allow a minimum ½ Space between glass panels.

**Solid Blocking must be provided for Standoff Clamps to be screwed into.**

See figure on pg. 2



### Balcony

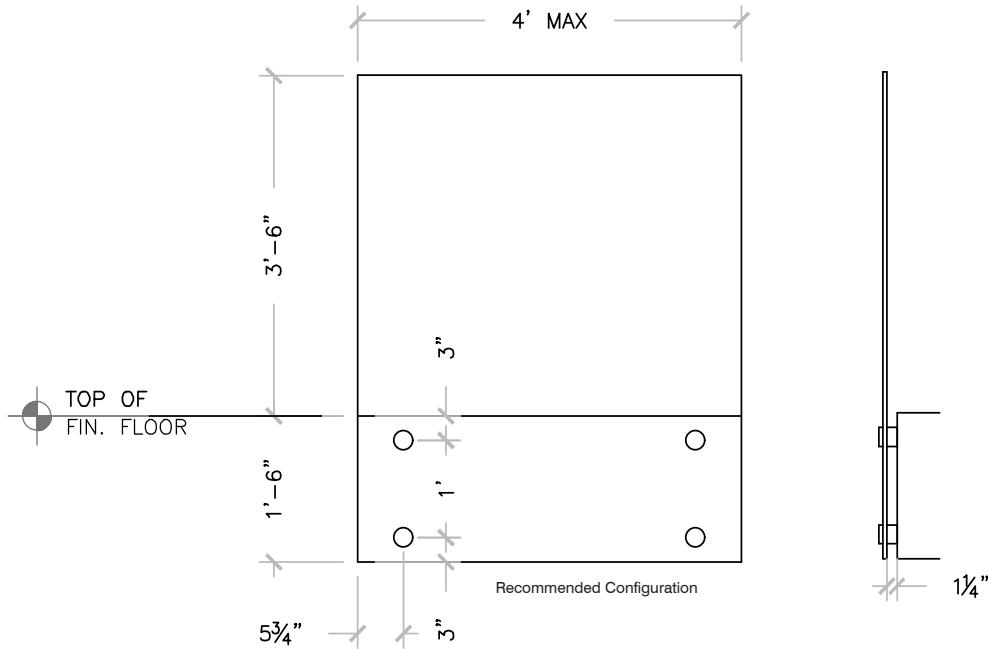

### Stairs

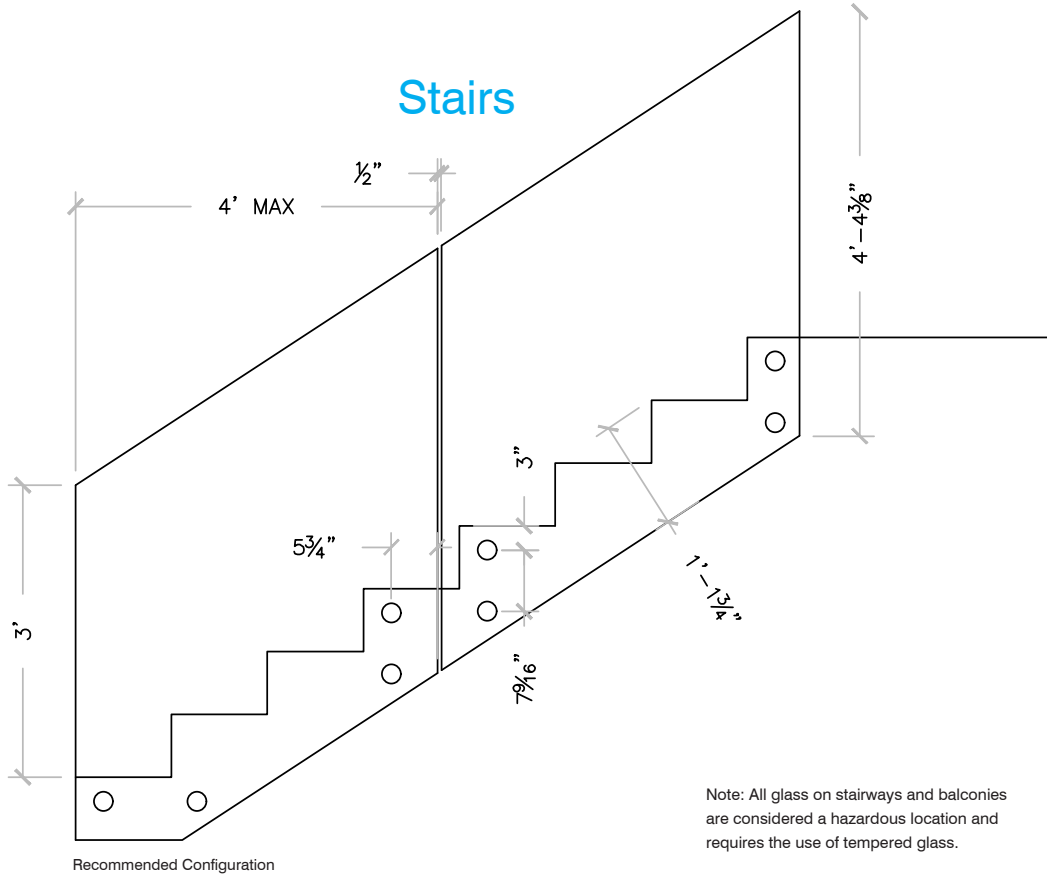

Note: All glass on stairways and balconies are considered a hazardous location and requires the use of tempered glass.

Note: Use flat polished edges on glass with radius or bumped corners when ordering glass from your glass supplier. All railing requires the use of tempered glass.

Cap rail required on glass for stairs to meet IRC code and recommended for balconies. Check your local municipality for requirements

2. Once layout has been completed, drill pilot hole for screws into wood or metal structure.
3. If Mounting Stand-off Glass Clamps directly on Sheetrock, sheetrock should be removed from behind glass clamp and install plywood of the appropriate thickness that is same thickness as the sheetrock e.g. ½" or 5/8" Plywood. By using a 1 ¼" Hole Saw (which is smaller than the diameter of the stand-off clamp) Glue and nail plywood plug in place.
4. Install AXIA Standoff clamp using 2-AX00.091.900.A.SP 6MM wood screws or 2-AX00.091.905.A.SP 6mm metal screws if mounting to metal stringer.
5. Once clamps are installed and tight to the mounting surface, remove outer half of clamps
6. Place 4 level vertically across clamps to check for plumb when glass is installed. Add Round Shim or Square Shim for 1/16" Shims. Stack up to make clamps vertically plumb before placing glass on the clamps.

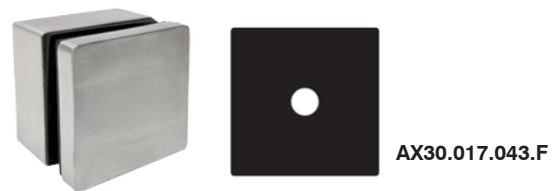

7. Cut ½" Plywood template to size of glass with desired spacing around panel and desired height of glass. Drill holes 1 ¼" in template (and glass) for glass clamps. This will allow for adjustment of glass panels once in place.
8. Install all templates in place and install and tighten glass clamp outer half.
9. Check margins around perimeter of glass to be even or equal measurements. Scribe as needed to make margins equal and even.

10. Once all margins have been adjusted, Number all templates, e.g. 1 of 15, 2 of 15, 3 of 15 etc. write Job name and address, glass type, thickness, edge treatment, corner treatment on every template. Make a template for each panel, even if it is the same size as another panel. Mark the desired location of tempered stamp on template. (inconspicuous but visible spot) If using Cap rail or U Channel be sure tempered stamp will be visible once installed and handrail is installed.

Note: if inspector can't see the etched tempered stamp, he will likely not pass the staircase for final inspection as he cannot determine it is tempered glass. Home inspectors on resale also look for this Tempered stamp and assures the homeowner it is tempered glass. Be sure to make a drawing of staircase to know location of panels and what number goes where. This will avoid confusion of where the glass panels go when receiving the glass.

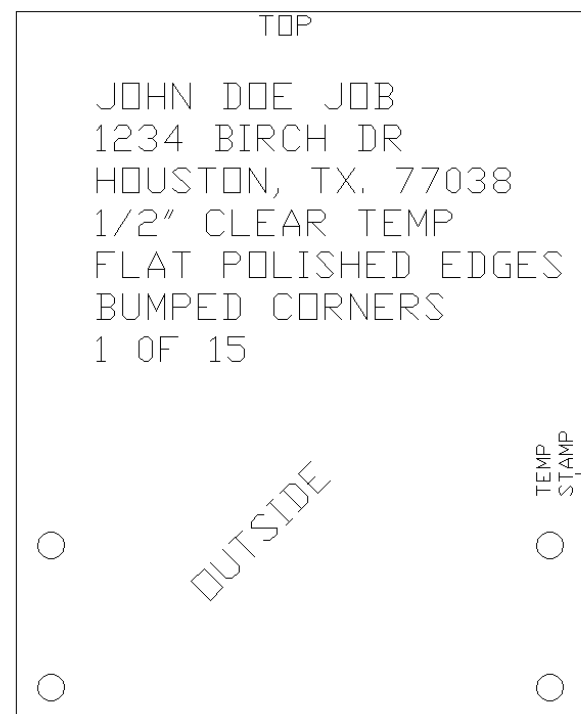



**11. Installing glass panels, use 2- Suction Cup lifters and two people are required.**

While one person is on balcony or stair holding panel in place, the other person is aligning up glass clamps to the glass panel and installing the outer half of the glass clamp. Install one on each side to relieve the person holding the weight of the glass. Install outer halves only hand tight.

**12. Install all the glass panels in place before tightening clamps**

**13. Check the spacing (margins) around the glass are equal dimensions loosen clamps and adjust panel as necessary to get equal dimensions around the panels.** Continue this with all the panels before tightening glass standoffs.

**14. Once all margins are correct, tighten glass clamps using the spanner wrench.** Do not overtighten. Spray lubrication between glass and clamp shim to allow to tighten freely.



AX30.070.530



AX30.070.531



**15. On the Square glass clamps use black electrical tape to attach the square shim to the outer half bring tape around the side and to the face of the outer half. Place a piece of this tape on all 4 sides of the square to firmly hold the gasket in place while tightening the clamp. Spray lubrication on the glass between the shim to allow gasket to turn freely while tightening.**

**16. Align square clamp so that is vertically aligned with wall side (back half) of clamps.**  
 If round be sure to put the tightening hole on edge of the outer half in an inconspicuous location

**17. Install Cap Rail on top of glass to keep panels from moving independently.**

**18. Clean Stainless Clamps with Degreaser and Polish.**



Cloth Rag



Step 2

Cleaner/Polish

AX00.080.510

## Glass Railing Systems

### U-CHANNEL INSTALLATION

- AX40.020.050.D.M** (U-Channel, floor mount, 16'-4" length)  
**AX40.020.051.D.M** (U-Channel, floor mount, 8'-2" length)  
**AX40.020.051.D.M** (U-Channel Cladding for floor mount, 8'-2" length)  
**AX40.023.272.D.M** (U-Channel inside corner, floor mount)  
**AX40.023.274.D.M** (U-Channel outside corner, floor mount)  
**AX40.021.285.R** (U-Channel glass gasket & wedge kit, covers 8'-2" length)

### TOOLS REQUIRED

- Power Drill
- Circular Saw
- Hammer Drill (for concrete mounting)
- Stainless Steel Cutting Saw (Cold Cut Saw, Bench top Portable Bandsaw, Chop Saw with Stainless Steel Cutting Blade)
- Axia Wedge Tool

### STEPS REQUIRED

For more detailed information on tools please visit:  
[www.axiarailing.com/recommended-tools](http://www.axiarailing.com/recommended-tools)

1. Layout Location of U-Channel on cap or floor
2. Measure and cut u channel sections to fit your balcony or stair.  
 AX40.020.050.D.M 16'4" Pcs or AX40.020.051.D.M 8'2" Pcs
3. Use premade corners for all 90-degree corners. AX40.023.272.D.M inside or AX40.023.274.D.M outside corner
4. Once all pieces are cut and placed, use drill bit to predrill holes for anchor screws if concrete drill correct size hole for drop in anchors. 1/2" X 2 1/2" drop in anchors or #14 x 3" wood screw with a 3/8" washer.
5. Install anchor bolts in predrilled holes. Check to make sure channel is plumb vertically, shim as necessary along length of U-Channel to make plumb / level. Tighten all anchor bolts.

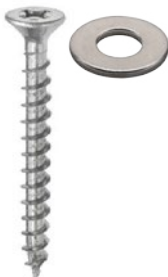
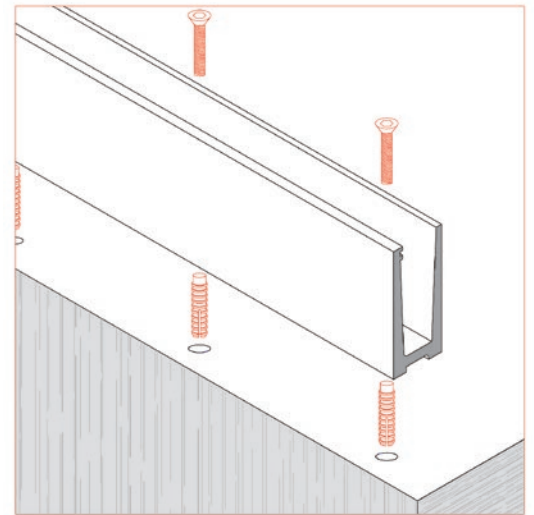

AX00.091.885.A.SP



AX00.091.880.A.SP



Composite Shims

AX00.110.710

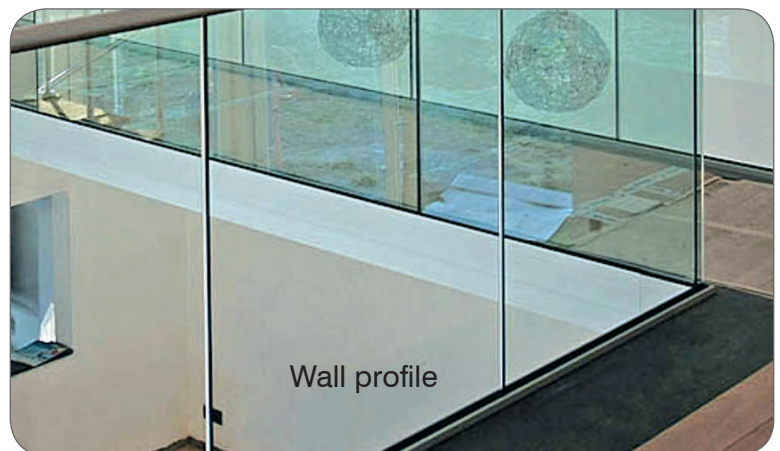
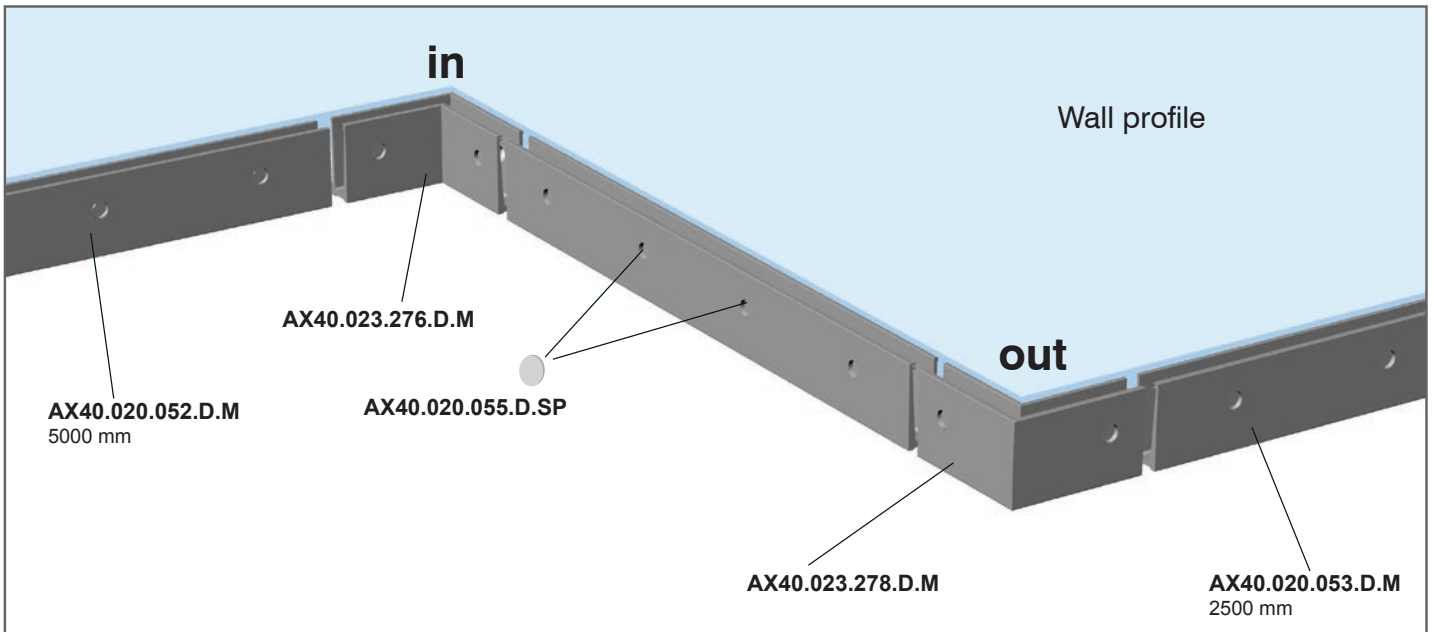
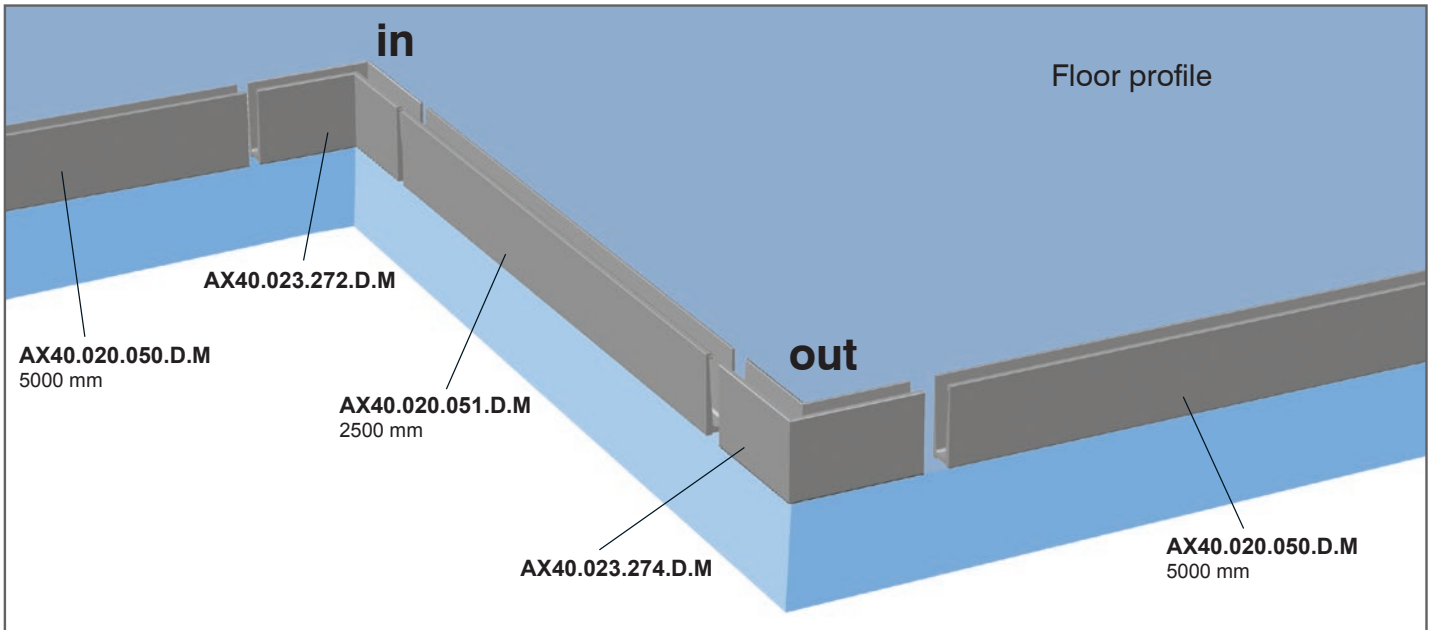

6. Cut ½ plywood templates for glass panels to the desired rail height and max 4' wide panels for ease of handling. Divide sections of rail evenly so all panels are equal measurements. Leave minimum ½" space between panels not to exceed 3 15/16" between panels, and between panel and wall.
7. Place white plastic shims in u channel on the F or forked side of U-Channel (the F should be on the outside edge of the U-Channel) white shims should be 2500 mm or approx. 10" O.C. along entire length of channel. See fig. on page 4
8. Place rubber t gasket in front of channel and press in place. See fig. on page 4
9. Install plywood panel into U-Channel by setting on white shim and pushing panel against outside the rubber gasket. See fig. on page 4
10. Install green shims on inside of U-Channel between plywood and channel 2 or 3 to hold template. See fig. on page 4
11. Check spacing of templates and make sure all margins (gaps) around templates are equal dimensions. Scribe as needed to make measurements equal. Once all margins have been adjusted, Number all templates, e.g. 1 of 15, 2 of 15, 3 of 15 etc. Write Job name and address, glass type, thickness, edge treatment, corner treatment on every template. Make a template for each panel, even if it is the same size as another panel.  
 Mark the desired location of tempered stamp on template. (inconspicuous but visible spot)  
 If using cap rail or u channel be sure tempered stamp will be visible once installed and handrail is installed. Note: If the inspector can't see the tempered stamp, they will likely not pass the staircase for final inspection as he cannot determine it is tempered glass. Home inspectors on resale will also look for this Tempered stamp and it assures the (buyer) homeowner that it is tempered glass.  
 Be sure to make a drawing of the staircase to know the location of panels and what number panel correspond to each location. This will avoid confusion of where the glass panels go when receiving the glass panels.

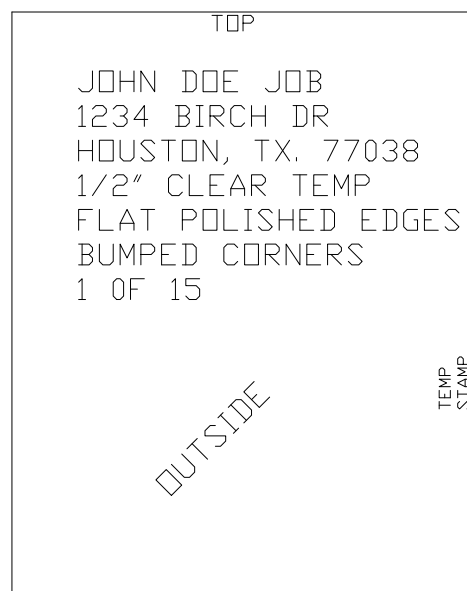



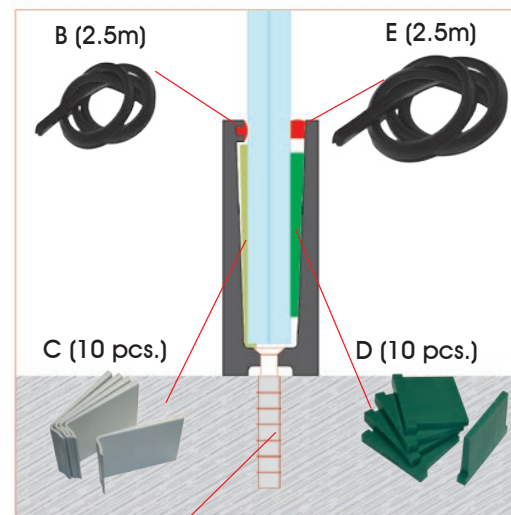
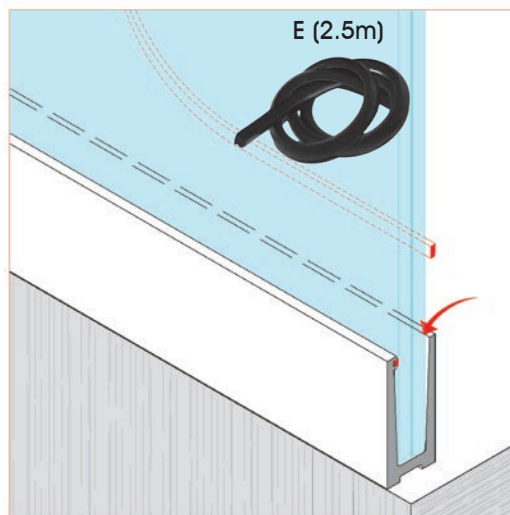
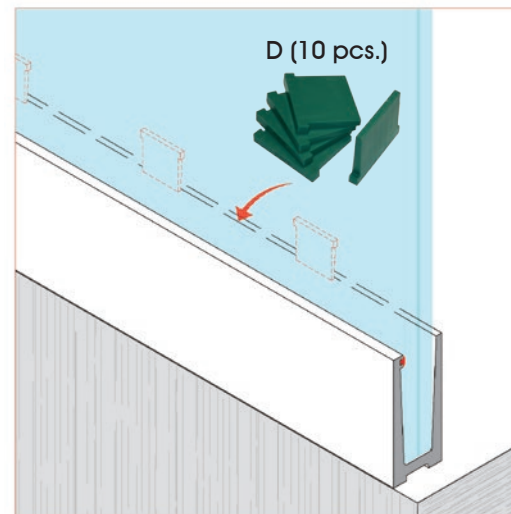
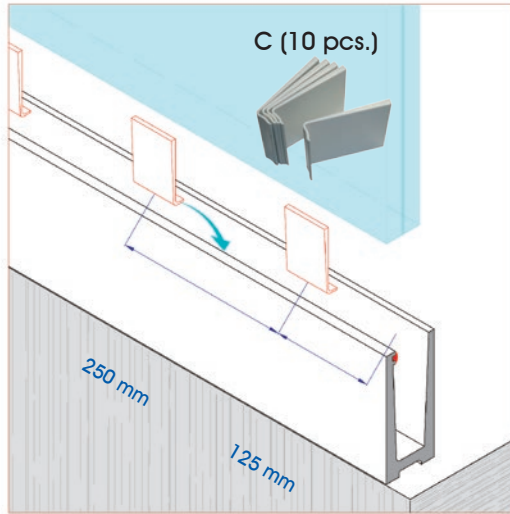
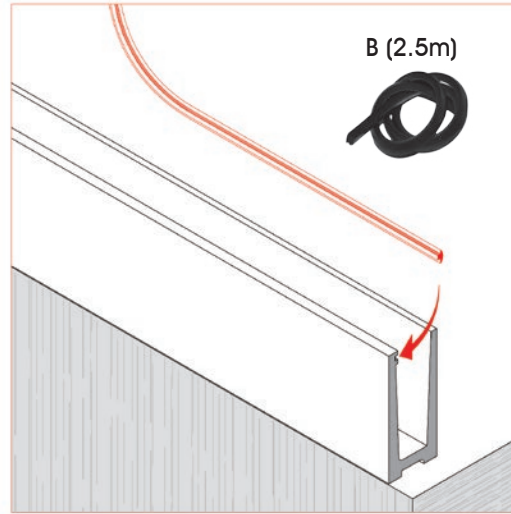
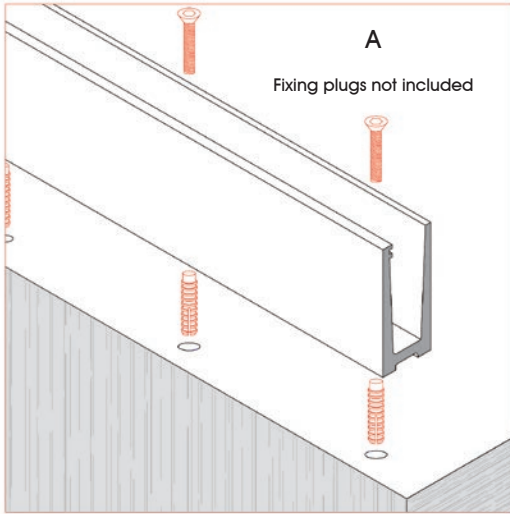

12. Installing glass panels in U-Channel. Place glass panel in U-Channel on white shim and against F (fork) rubber gasket. Install green shim between glass and inner side of channel. Using AXIA Multi-Function wedge tool drive the green shim down using mallet. Check glass for vertical plumb and drive shim as needed to make plumb. Green shims should be placed approx. every 10" on center and directly across from white shim on the opposite side of the glass. Quantity of 10 shims is needed for 8'2" length U-Channel and 20 shims for 16'4" length. See fig. on page 4



13. Check margins (gaps) around glass panels to make sure they are the same measurement and appear visually equal distance apart. Shim and adjust glass as necessary. If you need to remove green shims use tail hook on end of wedge tool and slide on each side of green shim and grab "ear" of shim on each side and then remove shim. Reinstall shim once glass is fully adjusted. See fig. on page 4

14. Once all glass panels are installed and gaps are equal, install the closing gasket on the inside top edge of the U-Channel (Included in Shim kit.) Spray U-Channel and glass at inside top edge of U-Channel with lubricant such as WD-40, place rubber closing gasket in between channel and glass and press firmly into place from one end to the other. Using the roller on the top side of the AXIA wedge tool roll the closing gasket into place. Clean all u channel with degreaser to remove lubricant. **Note: Stainless cladding will not adhere if all lubricant is not thoroughly removed from surface.** See fig. on page 4

15. Install stainless steel cladding on U-Channel, remove strip on double sided tape and press firmly onto U-Channel. Cut to length as needed to fit. If ends are exposed use the appropriate end cap for floor or wall profile / level or angle.



16. Clean all stainless steel cladding with degreaser then with cleaner/polish.



17. Install cap railing at this time.  
See [AXIA Installation Guide #11 - Glass Cap Rail Installation](#)



## Glass Railing Systems

### CAP RAIL INSTALLATION

- AX00.030.065.A.SP** (1.66" Round cap rail)  
**AX00.030.071.A.SP** (1.57" Square cap rail)  
**AX00.031.072.R** (Rubber gasket for cap rail)  
**S-2611** (100% Silicone sealant)

### TOOLS REQUIRED

- Caulking gun
- **Stainless Steel Cutting Saw** (Cold Cut Saw, Bench top Portable Bandsaw, Chop Saw with Stainless Steel Cutting Blade)

For more detailed information on tools please visit:  
[www.axiarailing.com/recommended-tools](http://www.axiarailing.com/recommended-tools)

### STEPS REQUIRED

1. Measure and cut rubber gasket to length.
2. Apply a bead of clear silicone on top of glass panels and place rubber gasket on top of glass by spreading U and pressing down onto glass working from one end setting the gasket into silicone sealant firmly.

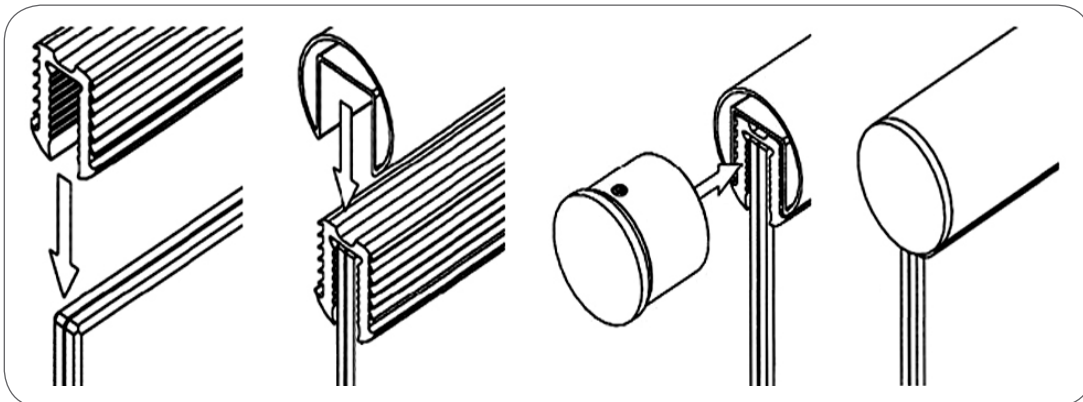

Apply clear silicone to glass before applying gasket, apply on top of gasket also before mounting cap rail.

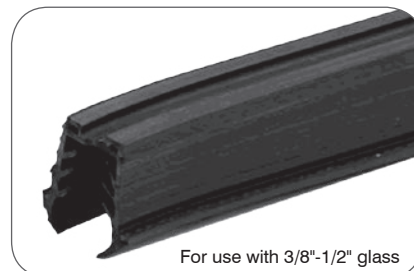

3. Install wall mount flanges in place at any wall terminations, round wall mount flange (and cover) or square wall mount flange (and cover) using 3" Long Stainless-Steel Screws (AX00.091.820.A.SP) into wood structure stainless steel screws. Pre-drill for screws using an 1/8" Bit. If exterior railing, put clear silicone in hole and on screw before installing screws. Apply bead of clear silicone on top and sides of flange at wall to seal water from getting behind the flange. Do not seal the bottom of the flange. Place 3/8 to 1/2 Dollop of silicone on each side of flange and slide cover onto flange, setting it into silicone sealant.



AX00.032.175.A.SP

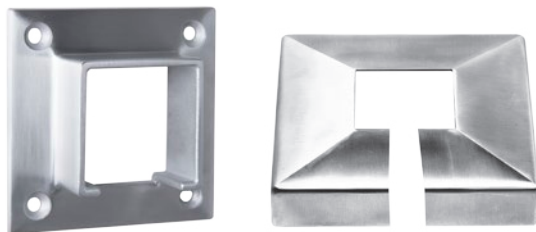

AX00.032.324.A.SP



4. Cut and fit Cap Rail tubing to fit at each section of railing. Use appropriate 90-degree fitting or adjustable fitting to make handrail continuous. dry fit all railing before gluing fitting together



5. Once all Rail is cut and fitted in place remove rail and glue fittings to Rail tubing using AXIA AX00.100.525 (Green) Anaerobic Adhesive. Place blue tape across joints while glue is drying to keep joints tight together. Place 3/8 bead of clear silicone on top of Rubber Gasket and set handrail on gasket, press down on rail to seat into gasket and firmly set into silicone sealant.

6. Clean all glue and Silicone with Mineral Spirits. Clean all Stainless with Degreaser and Polish

7. If Exterior Railing apply Passivator on Stainless Steel once all is clean and completed.



Scotch Brite Pads

AX00.080.505



Step 1

Degreaser

AX00.080.515



Cloth Rag



Step 2

Cleaner/Polish

AX00.080.510



Cloth Rag



Step 3 (required for exterior)

Polish/Passivator

AX00.080.517