

AXIA[®]

STAIR & RAILING SYSTEMS



STYLE



QUALITY



VALUE

AXIA[®]
STAIR & RAILING SYSTEMS

Full Product Line Catalog Edition 001-B



style

[stahyl]

noun

an elegant, fashionable, or luxurious mode of living: to live in style.

quality

[kwol-i-tee]

noun

high grade; superiority; excellence: railing of exceptional quality

value

[val-yoo]

noun

relative worth, merit, or importance: the value of a home

Stainless steel

In metallurgy, stainless steel, also known as inox steel or inox from French inoxydable (inoxidizable), is a steel alloy with a minimum of 10.5% chromium content by mass.

Stainless steel is notable for its corrosion resistance, and it is widely used for food handling and cutlery among many other applications.

Stainless steel does not readily corrode, rust or stain with water as ordinary steel does. However, it is not fully stain-proof in low-oxygen, high-salinity, or poor air-circulation environments.

There are various grades and surface finishes of stainless steel to suit the environment the alloy must endure. Stainless steel is used where both the properties of steel and corrosion resistance are required.

Stainless steel differs from carbon steel by the amount of chromium present. Unprotected carbon steel rusts readily when exposed to air and moisture. This iron oxide film (the rust) is active and accelerates corrosion by making it easier for more iron oxide to form. Since iron oxide has lower density than steel, the film expands and tends to flake and fall away. In comparison, stainless steels contain sufficient chromium to undergo passivation, forming an inert film of chromium oxide on the surface. This layer prevents further corrosion by blocking oxygen diffusion to the steel surface and stops corrosion from spreading into the bulk of the metal. Passivation occurs only if the proportion of chromium is high enough and oxygen is present in it.

Stainless steel’s resistance to corrosion and staining, low maintenance, and familiar lustre make it an ideal material for many applications.

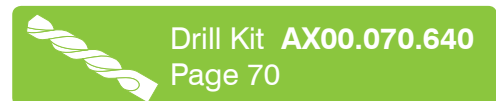
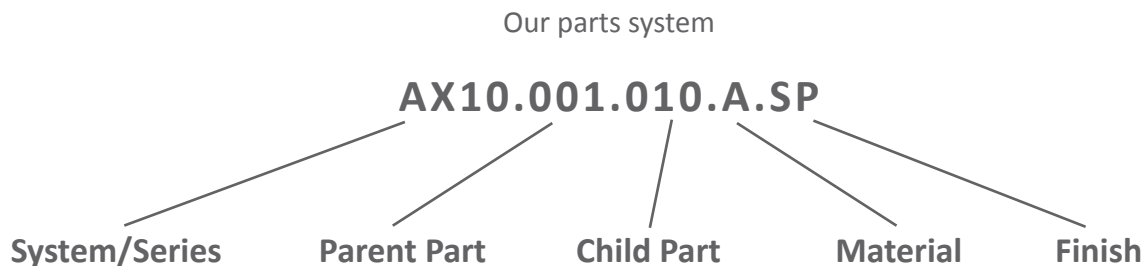

Parts that require adhesive

We offer a complete selection of the highest grade adhesives for professional installation.

Page 69

Parts that require hardware

Our parts are available with a full range of system hardware as well as anchors for mounting to wood and concrete.

Page 68

Installation kits available

Our complete offering of installation kits, tools and accessories makes it easy to professionally install our systems.

Page 70

Index

Post Railing Systems

ROUND SERIES



INFILL OPTIONS

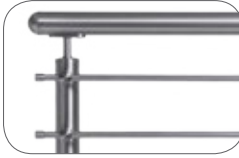

Round Tube Infill 4-7

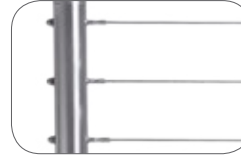

Cable Infill 8-13



Glass Clamps 14-17

POST OPTIONS



Round Post
Options 18-21

HANDRAIL OPTIONS



Round Handrail
Options 22-25

SQUARE SERIES



INFILL OPTIONS

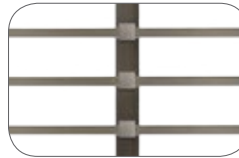

Bar/Tube Infill 26-29

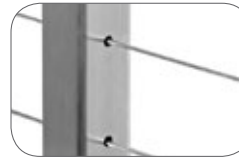

Cable Infill 30-35



Glass Clamps 36-39

POST OPTIONS

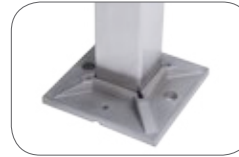

Square Post
Options 42-43



Wood Post
Options 42-43

HANDRAIL OPTIONS



Square Handrail
Options 42-45



Wood Handrail
Options 42-45

Glass Railing Systems

STANDOFF SERIES



STANDOFF OPTIONS



Round Standoffs
46-49



Square Standoffs
50-53

U CHANNEL SERIES



MOUNTING OPTIONS



Floor Mount 54-61



Wall Mount 54-61

CAP RAIL OPTIONS



Round Top rail
Options 62-65



Square Top rail
Options 66-67



Wood Top rail
66-67

ACCESSORIES



INSTALLATION



Hardware 68



Adhesives 69



Tools & Accessories
70-71



Specialty Tools 72



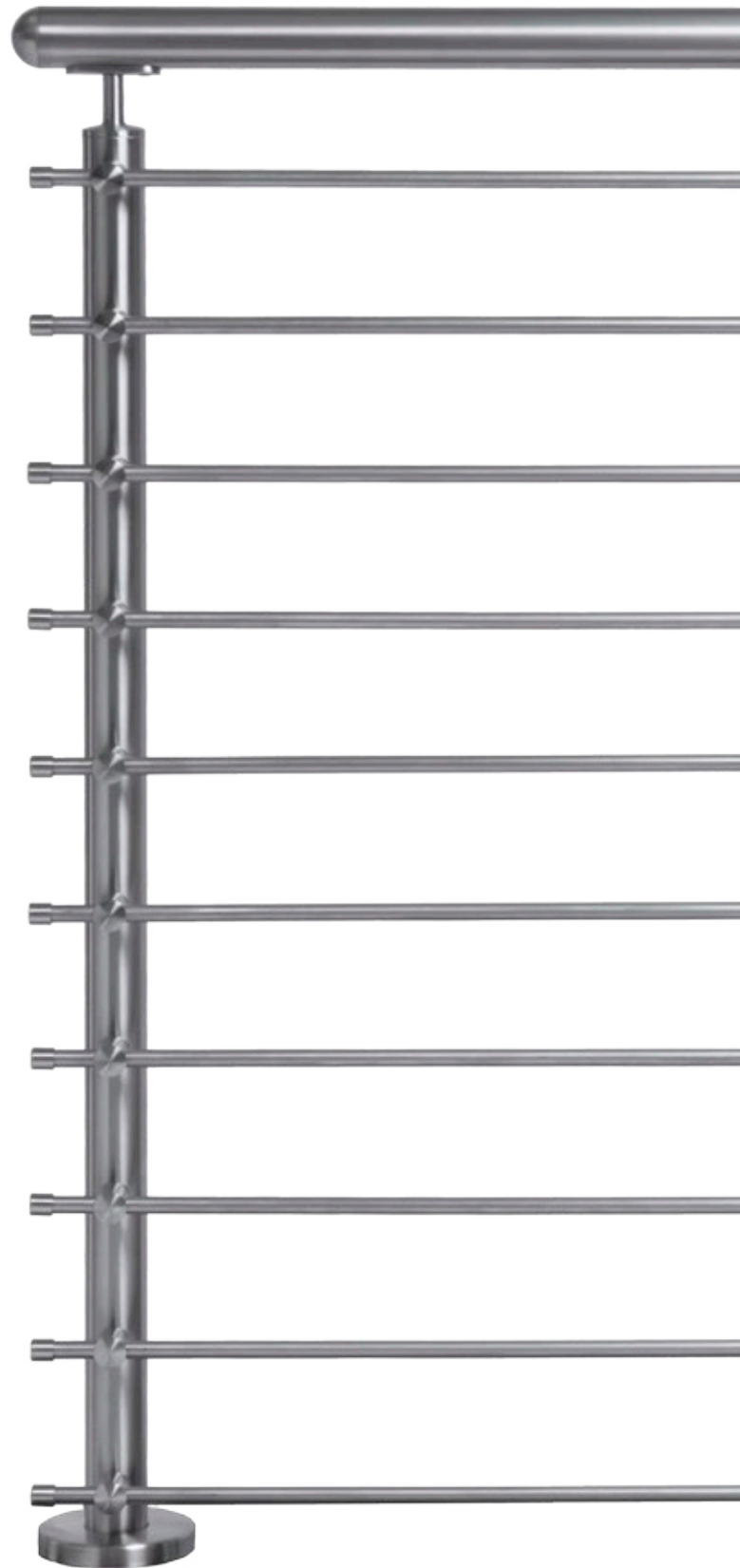

COD.	Ø	L	Wt.
AX10.009.83000.A.SP	12 x 1.5 mm	3000 mm (9'-10")	1.1 kgs (2.42 lbs)
AX10.009.85800.A.SP	12 x 1.5 mm	5800 mm (19')	2.1 kgs (4.64 lbs)

Round tube infill



See recommended tools section for information on cutting stainless steel.
www.axiarailing.com/recommended-tools

COD.	D	D2	MA
AX10.010.200.A.SP	42.4 mm	12 mm	6.5 mm

Round tube infill holder

Weight:
 .053 kgs (.117 lbs)

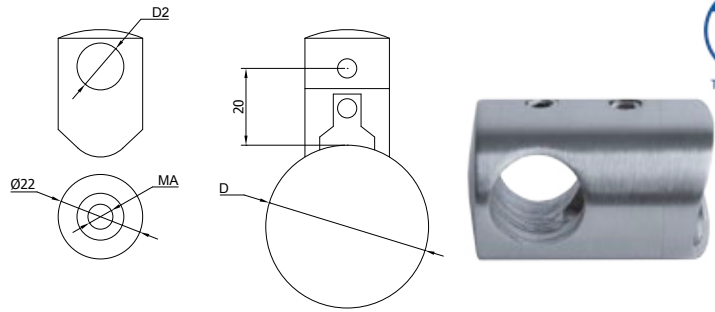

 Quick# 260X
 Page 68
 1 per location

COD.	B	A
AX10.010.206.A.SP	42.4 mm	12 mm

Round tube infill holder - connector

Weight:
 .054 kgs (.118 lbs)

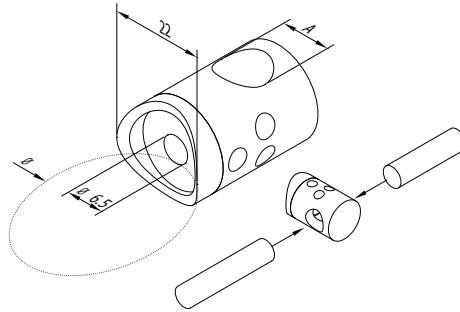



 Quick# 260X
 Page 68
 1 per location



COD.	Ø	L
AX10.010.082.A.SP	12 mm	36 mm

Inline connector

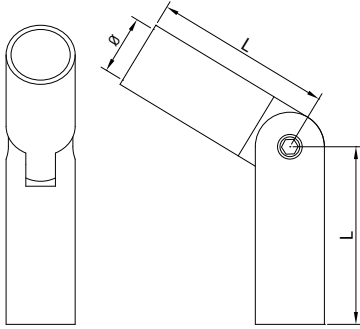
Weight:
.03 kgs (.066 lbs)

± 90° adjustable



COD.	X	D
AX10.010.209.A.SP	22 mm	12 mm

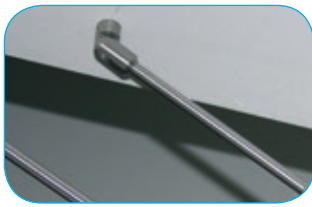

Inline holder for flat mount

Weight:
.126 kgs (.277 lbs)

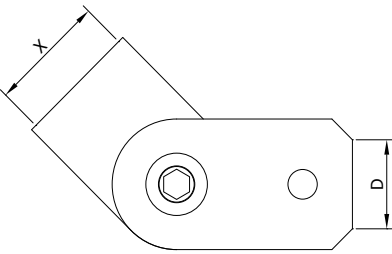

Quick# 820X
Page 68

1 per location



± 90° adjustable



COD.	D2	D3
AX10.010.208.A.SP	12 mm	12 mm

Cross holder

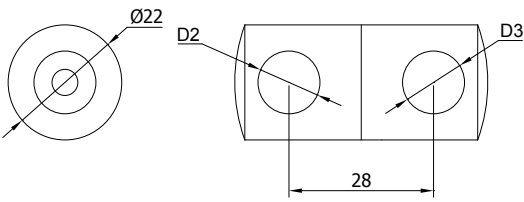

Weight:
.098 kgs (.216 lbs)

COD.	D	L
AX10.010.081.A.SP	12 mm	15 mm

End cap

Weight:
.011 kgs (.024 lbs)

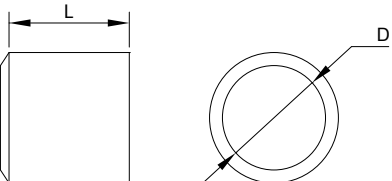



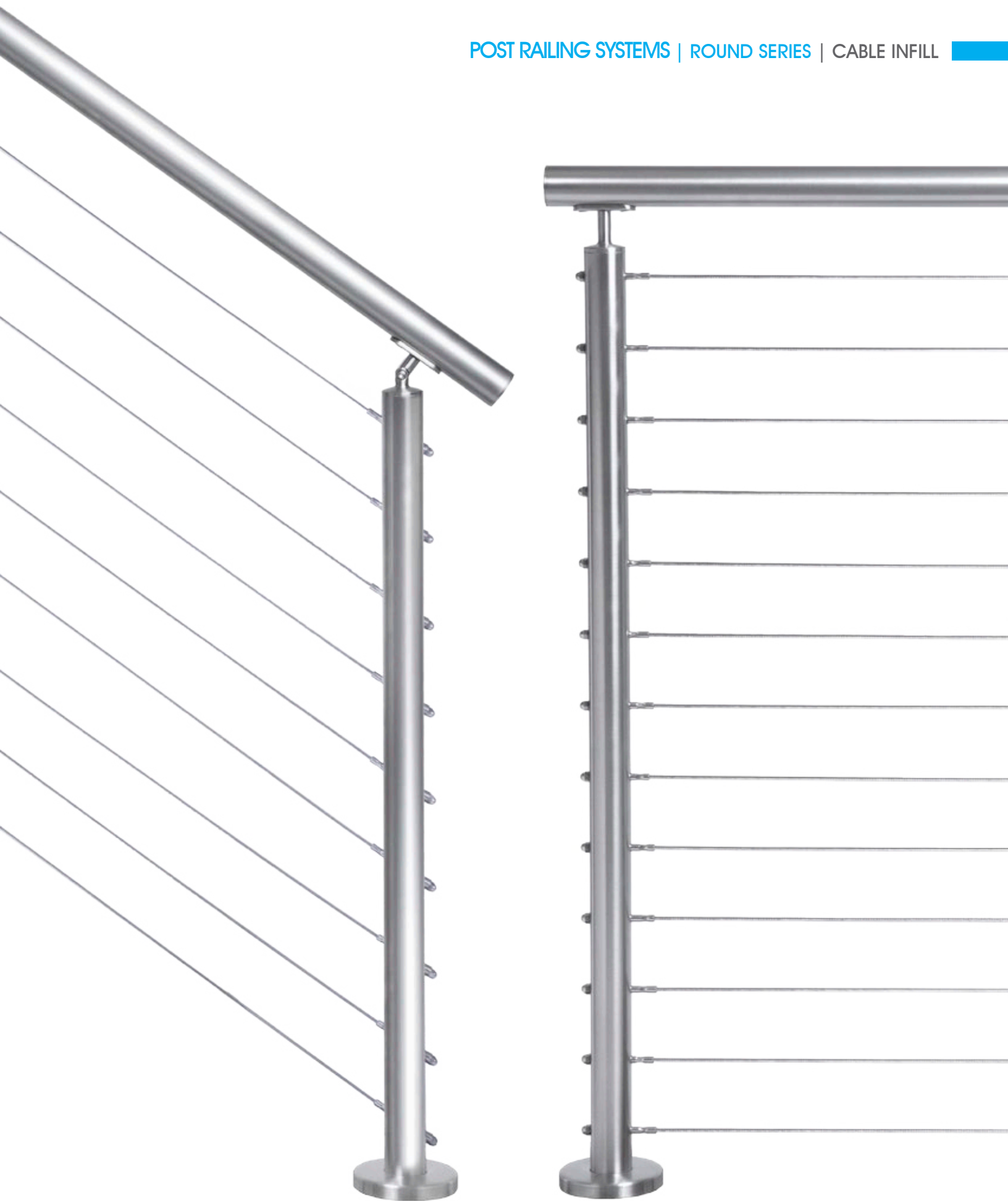

AISI 316



COD.	L	Wt.
HFC18.212-5	5'	.15 kgs (.331 lbs)
HFC18.212-10	10'	.227 kgs (.5 lbs)
HFC18.212-15	15'	.303 kgs (.669 lbs)
HFC18.212-20	20'	.383 kgs (.844 lbs)
HFC18.212-25	25'	.549 kgs (1.2 lbs)

Outside to outside
Level/balcony or angle/rake
Steel posts

Drill Kit AX00.070.640
Page 70



AISI 316



COD.	L	Wt.
HFC18.102-5	5'	.15 kgs (.331 lbs)
HFC18.102-10	10'	.227 kgs (.5 lbs)
HFC18.102-15	15'	.303 kgs (.669 lbs)
HFC18.102-20	20'	.383 kgs (.844 lbs)
HFC18.102-25	25'	.549 kgs (1.2 lbs)

Outside to outside
Level/balcony or angle/rake
Steel or wood posts

Drill Kit AX00.070.630
AX00.070.635 Page 70



AISI 316



COD.	L	Wt.
HFC18.401-5	5'	.15 kgs (.331 lbs)
HFC18.401-10	10'	.227 kgs (.5 lbs)
HFC18.401-15	15'	.303 kgs (.669 lbs)
HFC18.401-20	20'	.383 kgs (.844 lbs)
HFC18.401-25	25'	.549 kgs (1.2 lbs)

Inside to inside
Level/balcony

Drill Kit AX00.070.645
Page 70



AISI 316



COD.	L	Wt.
HFC18.500M-5	5'	.15 kgs (.331 lbs)
HFC18.500M-10	10'	.227 kgs (.5 lbs)
HFC18.500M-15	15'	.303 kgs (.669 lbs)
HFC18.500M-20	20'	.383 kgs (.844 lbs)
HFC18.500M-25	25'	.549 kgs (1.2 lbs)

Inside to inside
Level/balcony or angle/rake

Drill Kit AX00.070.650
Page 70

AISI 316



1 x 19 Cable - 1/8" Diameter



AISI 316



Available in 328' spool

COD.	Dim. mm	Length	kg/100 m
AX00.040.215.B.M	4 mm	100 m	6.14

1x19 Cable - Bulk(4mm 316)

Weight:
8.5 kgs (18.73 lbs)

COD.	G	mm	L1	L2	L3	D	A	kg/100
AX00.050.220DX.B.SP	M6	4	88	30	50	7	4.5	1.2

Right handed cable terminal stud (DX)

Weight:
.016 kgs (.035 lbs)

AISI 316

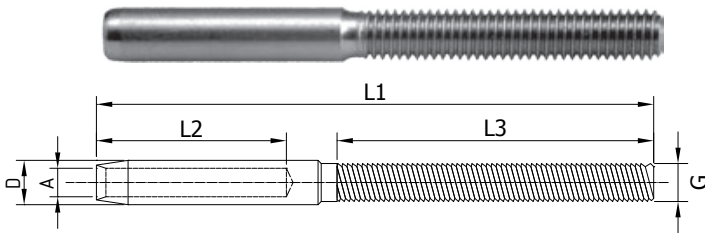

For use with 4mm cable

Hydraulic crimper



Page 72

Drill Kit AX00.070.610
Page 70

COD.	G	mm	L1	L2	L3	D	A	kg/100
AX00.050.221SX.B.SP	M6	4	88	30	50	7	4.5	1.2

Left handed cable terminal stud (SX)

Weight:
.016 kgs (.035 lbs)

AISI 316

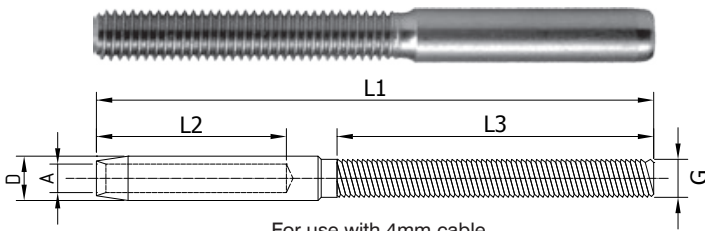

For use with 4mm cable

Hydraulic crimper



Page 72

Drill Kit AX00.070.610
Page 70

AISI 316



For use with 4mm cable

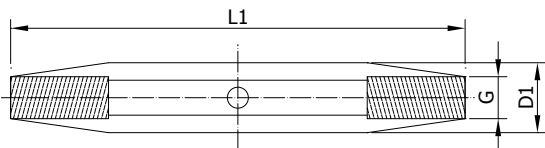

COD.	G	L1	D1	kg/100
AX00.050.235.B.SP	M6	65	10	1.7

Middle-tensioning body

Weight:
.025 kgs (.055 lbs)



COD.	NV	G	kg/100
AX00.050.231SX.B.SP	10	M6	0.9 LEFT
AX00.050.230DX.B.SP	10	M6	0.9 RIGHT

Threaded nut caps tensioner

Weight:
.006 kgs (.013 lbs)

Drill Kit **AX00.070.610**
Page 70

AISI 316



For use with 4mm cable

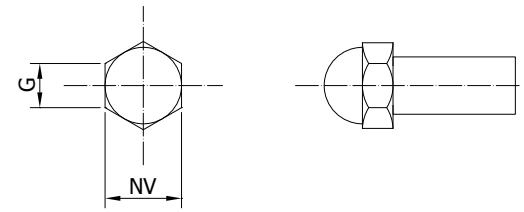

AISI 316

COD.	d	Ø	e
AX10.060.240.B.SP	10 mm	42.4 mm	12 mm ROUND

Sloping washer for round posts

Weight:
.006 kgs (.013 lbs)

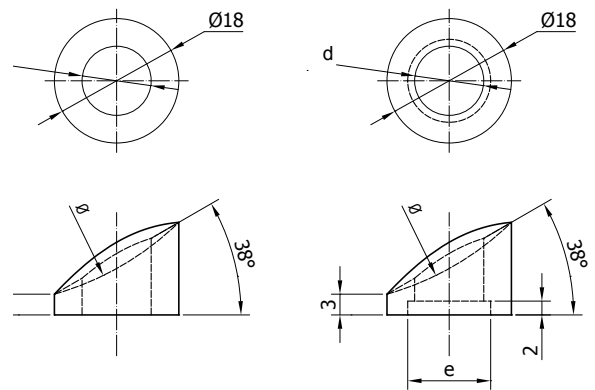





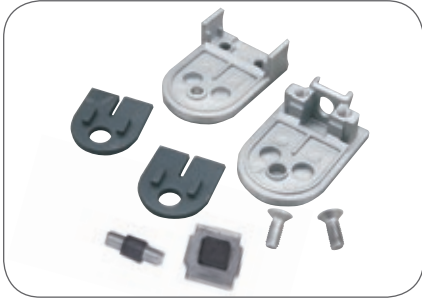

Use thread lock on all screws
AX00.100.563

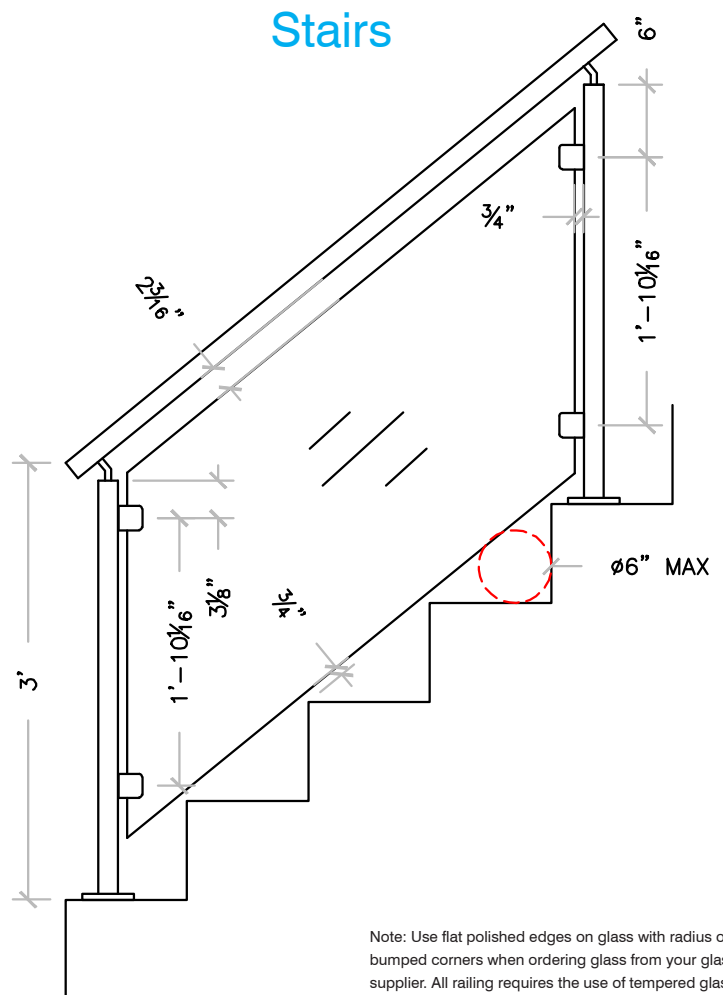
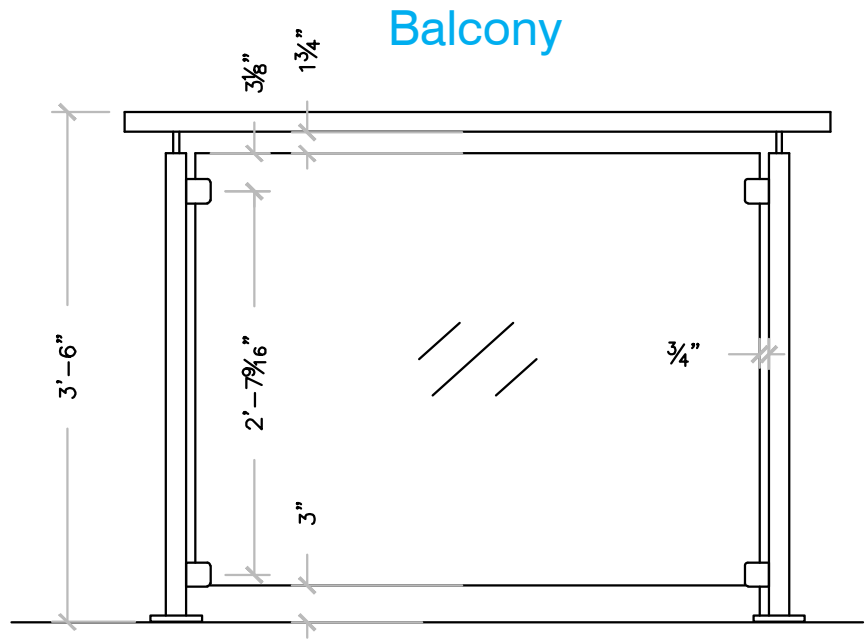

Note: Use flat polished edges on glass with radius or bumped corners when ordering glass from your glass supplier. All railing requires the use of tempered glass.

COD.	Ø	L
------	---	---

AX10.014.180.A.SP 42.4 mm 10 - 12.76 mm

Glass clamps for round posts

Weight:
.303 kgs (.667 lbs)

Rubber inserts not included
Available for 3/8" & 1/2" monolithic glass

 Quick# 255X
Page 68

1 per location

Note: All glass on stairways and balconies are considered a hazardous location and requires the use of tempered glass.

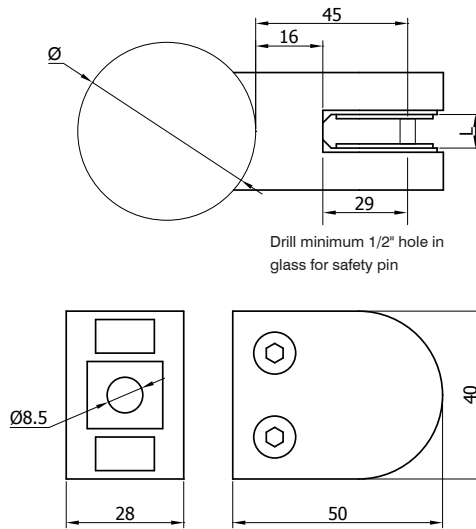

Swift plate and safety pin included

Note: Safety pin or swift plate can be used to support glass.

COD.	T
------	---

AX10.015.182R 10 mm for 3/8" glass

AX10.015.183R 12 mm for 1/2" glass

Glass clamp inserts

Weight:
.009 kgs (.02 lbs)

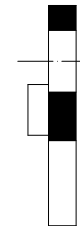
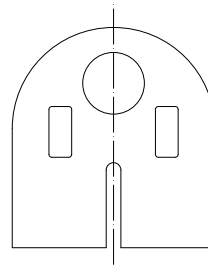

sold in pairs



COD.	Size	ØD
AX00.090.266.A.SP	M5	6.9 mm
AX00.090.267.A.SP	M6	8.9 mm
AX00.090.269.A.SP	M8	10.9 mm

Pop rivets - threaded inserts

Weight:
.0018 kgs (.004 lbs)
.0027 kgs (.006 lbs)
.0045 kgs (.01 lbs)

Provides stronger connection for all system screws:
handrail, bar holders and glass clamps
No tapping Required

 Quick# 250X, 255X,
260X Page 68

Sold individually



Pop rivet tool

Page 72

COD.	Ø	ØBase	Height
AX10.001.001.A.SP	42.4 mm	101 mm	1000 mm (39-3/8")

Round post - floor mounted

Weight:
2.34 kgs (5.15 lbs)

 Clear Silicone

 Flange cover included

 Quick# 800X, 805X
Page 68

3 per location

See recommended tools section for information on cutting stainless steel.
www.axiarailing.com/recommended-tools

COD.	Ø	D
AX10.008.142.A.SP	105 mm	42.75 mm

Replacement Flange cover - floor mounted

Weight:
.086 kgs (.189 lbs)

 Clear Silicone

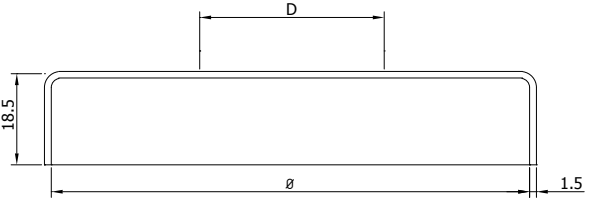
 18.5, D, 1.5

COD.	Ø
AX10.001.003.D.M	42.4 mm

Core mount

Weight:
.849 kgs (1.87 lbs)

 Epoxy

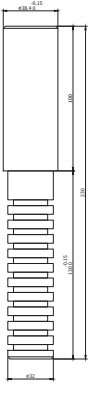

COD.	Ø	D
AX10.008.143.A.SP	105 mm	42.75 x 60 mm

Angled flange cover - core mount

Weight:
.117 kgs (.257 lbs)

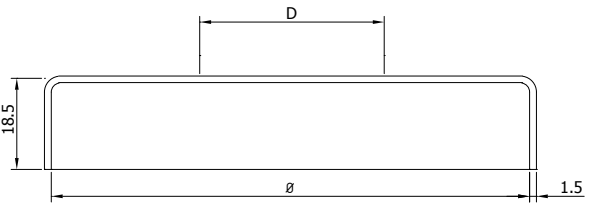

 Clear Silicone
up to 40 degrees

 18.5, D, 1.5

AX10.004.063.3000.A.SP (Rd. Tubing)
 AX10.004.063.5800.A.SP (Rd. Tubing)
 AX20.004.070.3000.A.SP (Sq. Tubing)
 AX20.004.070.5800.A.SP (Sq. Tubing)

Cut tubing to length at wall angle

Glue tubing to core mount stem using anaerobic adhesive AX00.100.525 Page 69

Epoxy core mount stem to structure/blocking EPC-410 Epoxy Page 69

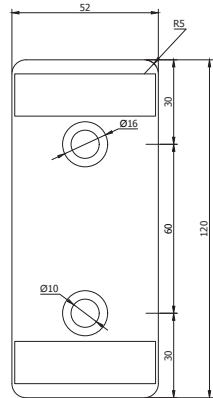
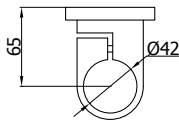

COD.	Ø
AX10.001.002.A.SP	42.4 mm

Wall mount

Weight:
.394 kgs (.869 lbs)

Quick#900X, 905X
Page 68

2 per location

Note: Use round tube handrail for posts(Page 22)

AX10.004.063.3000.A.SP
AX10.004.065.5800.A.SP

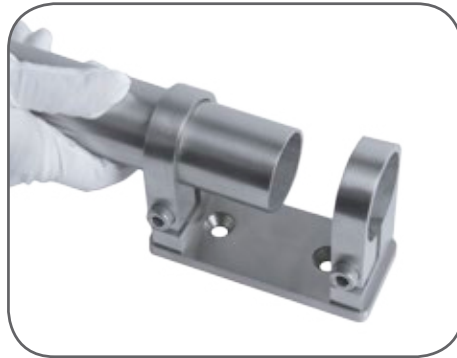

AX10.007.120.A.SP

AX10.007.121.A.SP



See page 22

Note: End caps should be used on the bottom of the posts.



COD.	Ø	D
AX10.005.020.A.SP	42.4 x 2 mm	42.4 mm





Post handrail support

Weight:
.174 kgs (.383 lbs)

 Quick# 250X, 540X
Page 68

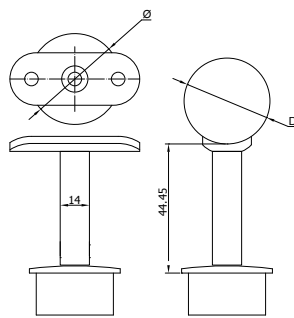
Option: Use M5 pop rivets to attach handrail AX00.090.266.A.SP

2 per location







Round saddle included
Flat saddles available (Page 41)

COD.	Ø	D
AX10.005.021.A.SP	42.4 x 2 mm	42.4 mm



Post handrail support - adjustable

Weight:
.164 kgs (.361 lbs)

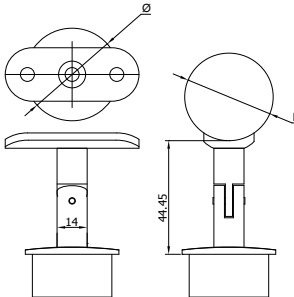

 Quick# 250X, 540X
Page 68

Option: Use M5 pop rivets to attach handrail AX00.090.266.A.SP

2 per location

20° - 90° adjustable





Round saddle included
Flat saddles available (Page 41)

COD.	Ø	D
AX10.005.026.A.SP	42.4 x 2 mm	42.4 mm





Rail support - beveled/coped

Weight:
.118 kgs (.26 lbs)

 Quick# 260X
Page 68

Option: Use M6 pop rivets to attach handrail AX00.090.267.A.SP

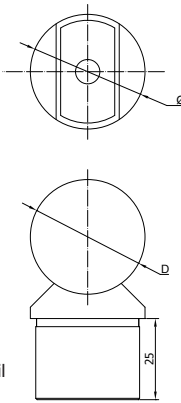
For use on level balconies only

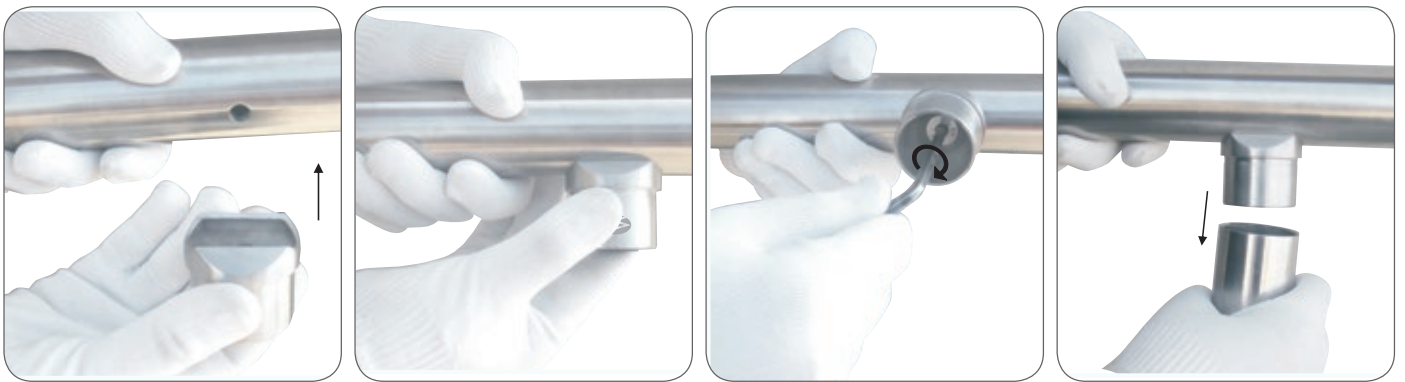





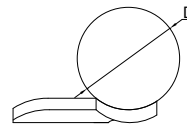
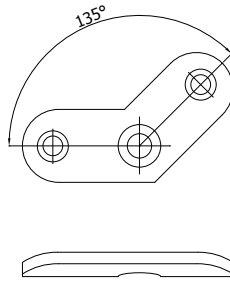
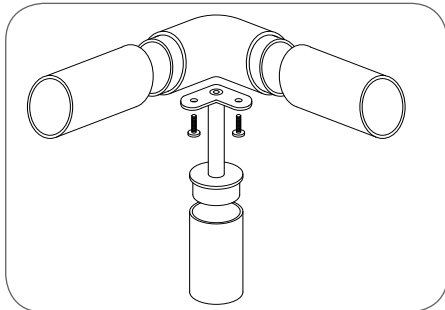

COD. D

AX10.005.022.A.SP 42.4 mm

45 degree saddle

Weight:
.047 kgs (.103 lbs)



Quick# 250X, 540X
Page 68

2 per location

COD. D

AX10.005.023.A.SP 42.4 mm

90 degree saddle

Weight:
.036 kgs (.079 lbs)

Quick# 250X, 540X
Page 68

2 per location

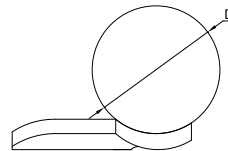
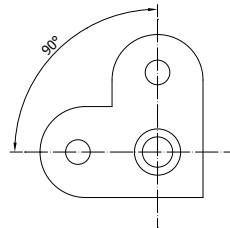

COD. D

AX10.005.024.A.SP 42.4 mm

Saddle - 180 degree - round

Weight:
.037 kgs (.081 lbs)

Quick# 250X, 540X
Page 68

2 per location

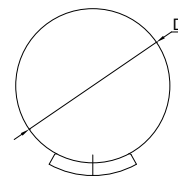
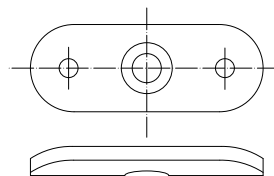

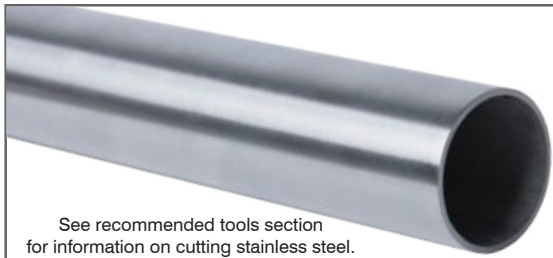

COD.	Ø	L
------	---	---

AX10.004.063.3000.A.SP	42.4 x 2 mm	3000 mm (9'-10")
AX10.004.065.5800.A.SP	42.4 x 2 mm	5800 mm (19')

Round tube handrail/post

Weight:
6.2 kgs (13.64 lbs)
11.9 kgs (26.18 lbs)

See recommended tools section for information on cutting stainless steel.
www.axiarailing.com/recommended-tools

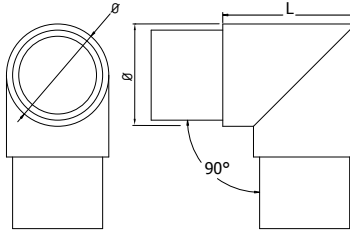

COD.	Ø	L
------	---	---

AX10.008.100.A.SP	42.4 x 2 mm	50 mm
--------------------------	-------------	-------

90 degree elbow

Weight:
.266 kgs (.585 lbs)

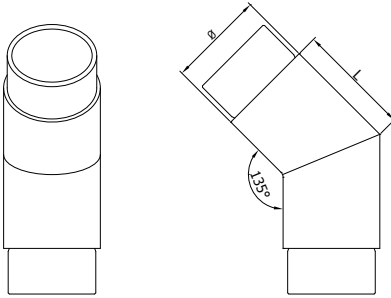

COD.	Ø	L
------	---	---

AX10.008.101.A.SP	42.4 x 2 mm	50 mm
--------------------------	-------------	-------

45 degree elbow

Weight:
.316 kgs (.695 lbs)



± 90° adjustable

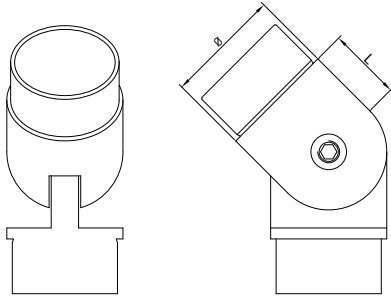

COD.	Ø	L
------	---	---

AX10.008.102.A.SP	42.4 x 2 mm	50 mm
--------------------------	-------------	-------

Adjustable ± 90 degree elbow

Weight:
.379 kgs (.834 lbs)

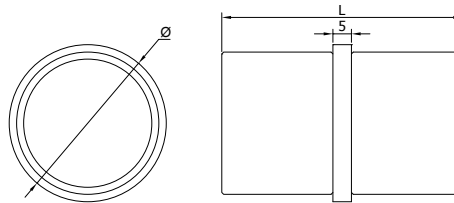

COD.	Ø	L
------	---	---

AX10.008.103.A.SP	42.4 x 2 mm	50 mm
--------------------------	-------------	-------

Connector

Weight:
.121 kgs (.166 lbs)

COD.	Ø
------	---

AX10.007.120.A.SP	42.4 x 2 mm
--------------------------	-------------

Flat end cap

Weight:
.057 kgs (.125 lbs)

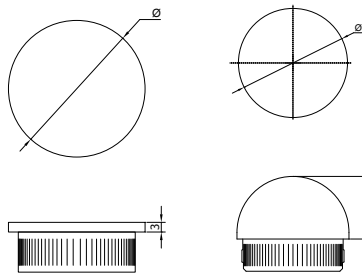





COD.	Ø	H
------	---	---



AX10.007.121.A.SP	42.4 x 2 mm	21 mm
--------------------------	-------------	-------

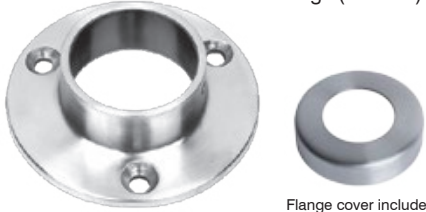

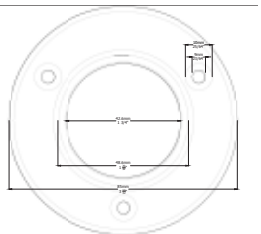
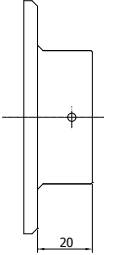

Round end cap

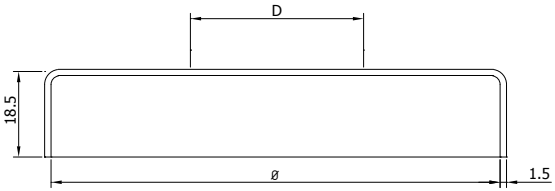

Weight:
.072 kgs (.158 lbs)



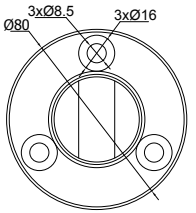
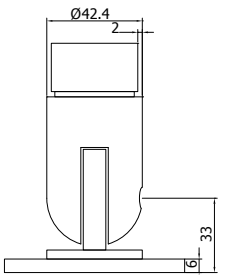



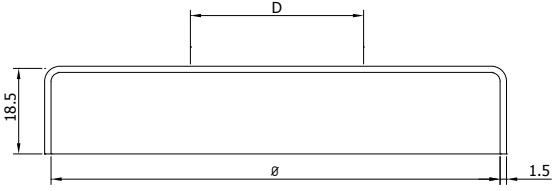

COD.	Ø	D
AX10.008.140.A.SP	80 mm	42.4 mm
Wall mount flange		
Weight: .202 kgs (.444 lbs)		
		
Flange cover included		
		
3 per location		

COD.	Ø	D
AX10.008.139.A.SP	89.7 mm	50 mm
Replacement Flange cover		
Weight: .099 kgs (.219 lbs)		
		
		

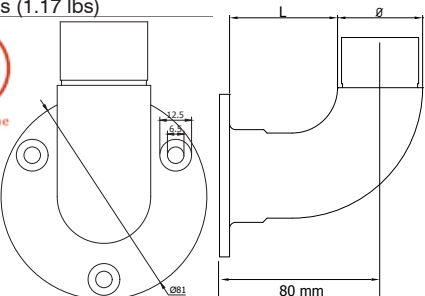
COD.	Ø	D
AX10.008.141.A.SP	42.4 x 2 mm	
Adjustable wall mount flange		
Weight: .1 kgs (.22 lbs)		
		
± 90° adjustable		
Flange cover included		
		
3 per location		

COD.	Ø	D
AX10.008.144.A.SP	84.6 mm	42.9 mm
Replacement Flange cover		
Weight: .054 kgs (.119 lbs)		
		
		

COD.	Ø	L
AX10.033.104.A.SP	42.4 x 2 mm	54 mm
Wall rail return flange		
Weight: .533 kgs (1.17 lbs)		
		
Flange cover included		
		
3 per location		

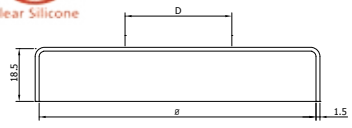
COD.	Ø	D
AX10.033.105.A.SP	86 mm	46.5 mm
Replacement Flange cover		
Weight: .097 kgs (.213 lbs)		
		
		

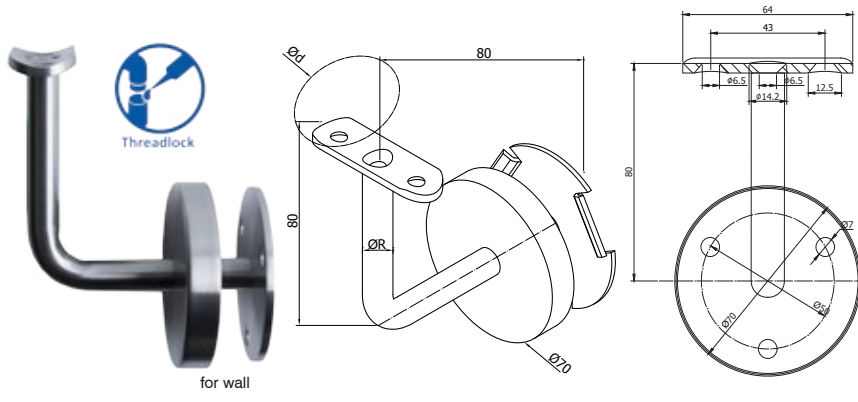

COD.	Ø	R	Ød
AX10.033.023.A.SP	70 mm	12 mm	42.4 mm

Wall handrail support

Flat saddle sold separately for flat rail options

Weight:
.275 kgs (.605 lbs)

-  Quick# **250X** - 2 per location
- Quick# **540X** - 2 per location
- Quick# **855X** - 3 per location
- Page 68



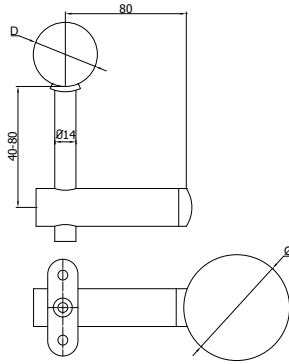



COD.	Ø	Ød
AX10.033.025.A.SP	42.4 mm	42.4 mm

Post handrail support

Flat saddle sold separately for flat rail options

Weight:
.457 kgs (1.01 lbs)

-  Quick# 250X - 2 per location
-  Quick# 540X - 2 per location
-  Quick# 260X - 1 per location
- Page 68

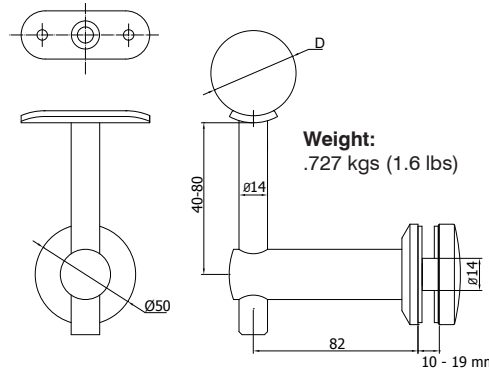
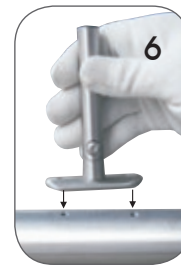
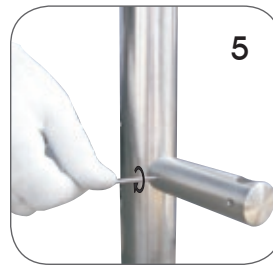
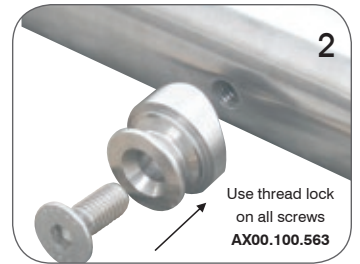
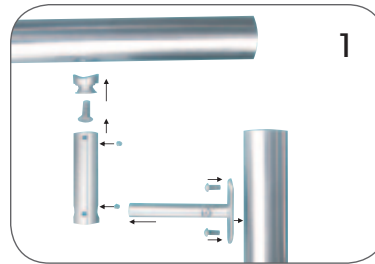
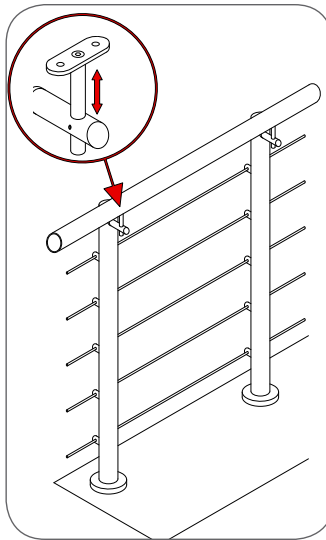
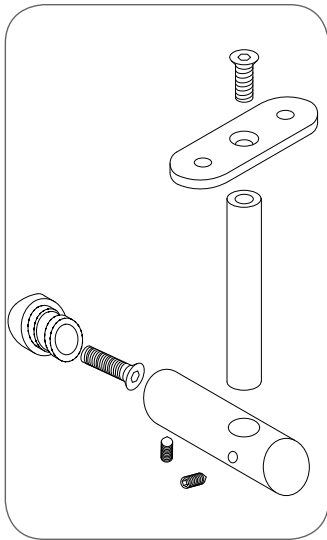

Weight:
.727 kgs (1.6 lbs)

COD.	Ød
AX10.033.024.A.SP	42.4 mm

Glass handrail support

Flat saddle sold separately for flat rail options

-  Quick# 250X, 540X
- Page 68
- 2 per location



For use on 12mm(1/2") tempered glass

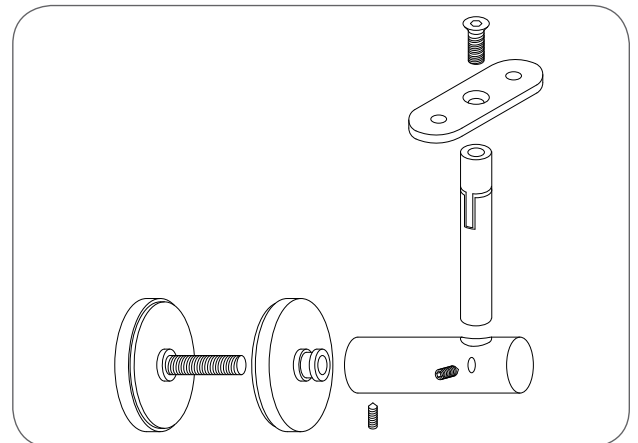
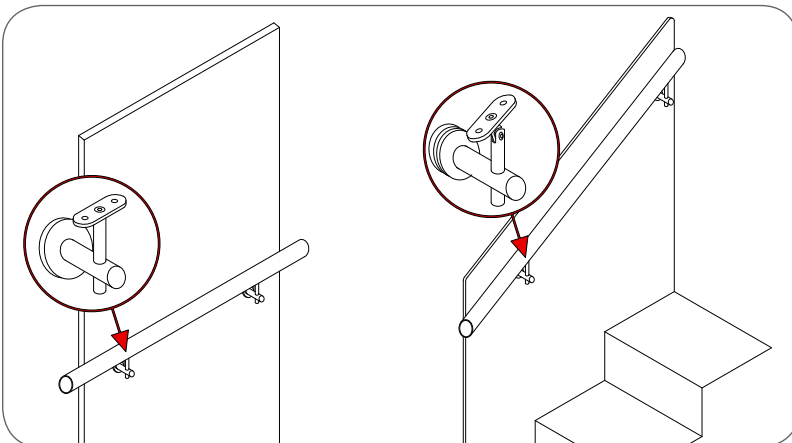



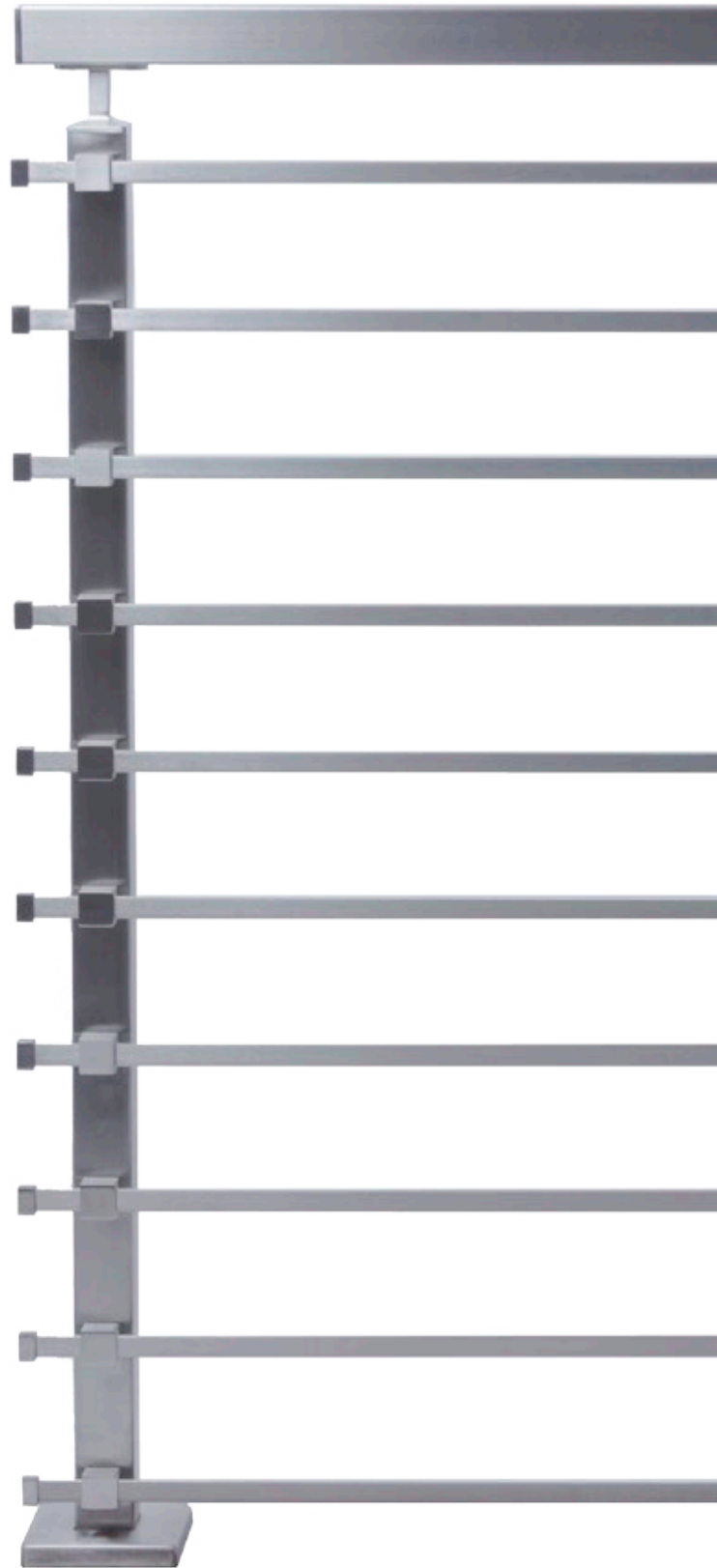

COD.	Ø	L
AX20.009.090.A.SP	15 x 5 mm	5800 mm (19')

Flat bar infill

Weight:
3.02 kgs (6.64 lbs)



See recommended tools section for information on cutting stainless steel.
www.axiarailing.com/recommended-tools

COD.	X	D
AX20.010.093.A.SP	flat	15 x 5 mm

Bar holder

Weight:
.095 kgs (.209 lbs)

 Quick# 260X
Page 68

1 per location

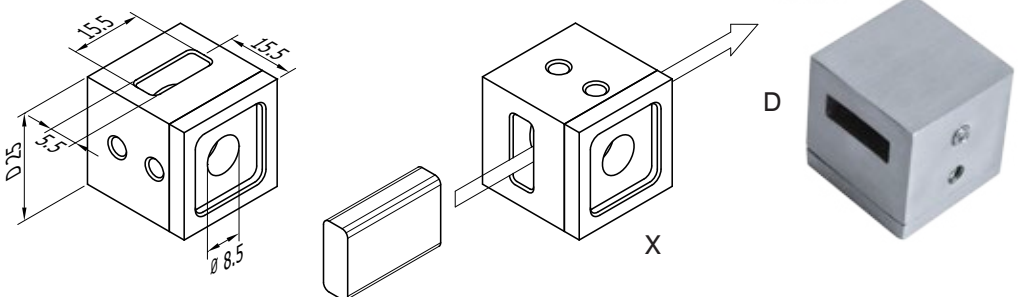



 Threadlock

COD.	D
AX20.010.091.A.SP	15 x 5 mm

Adjustable connector

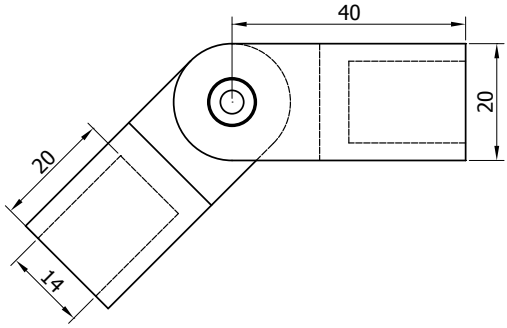
Weight:
.134 kgs (.294 lbs)

 Anaerobic Adhesive

adjustable up to 55°

COD.	D
AX20.010.092.A.SP	15 x 5 mm

End cap

Weight:
.014 kgs (.031 lbs)

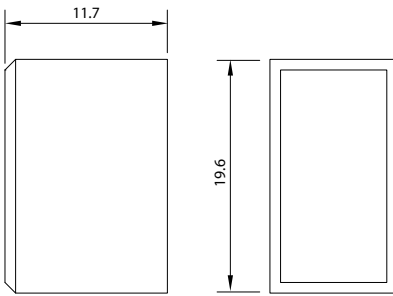
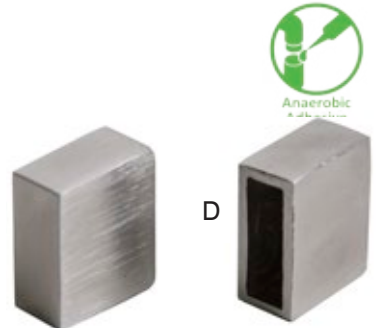



 Anaerobic Adhesive

COD.	Ø	L
AX10.009.83000.A.SP	12.0 x 1.5 mm	3000 mm (9'-10")
AX10.009.85800.A.SP	12.0 x 1.5 mm	5800 mm (19')

Round tube infill

Weight:
 1.1 kgs (2.42 lbs)
 2.11 kgs (4.64 lbs)





See recommended tools section for information on cutting stainless steel.
www.axiarailing.com/recommended-tools

COD.	D	D2	MA
AX10.010.205.A.SP	flat	12 mm	6.5 mm

Round tube holder - flat

Weight:
 .053 kgs (.117 lbs)

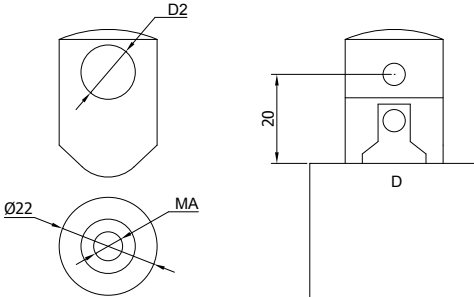

Quick# 260X
 Page 68
 1 per location

COD.	Ø	L
AX10.010.082.A.SP	hole 12 mm	30 mm

Adjustable round tube connector

Weight:
 .03 kgs (.066 lbs)

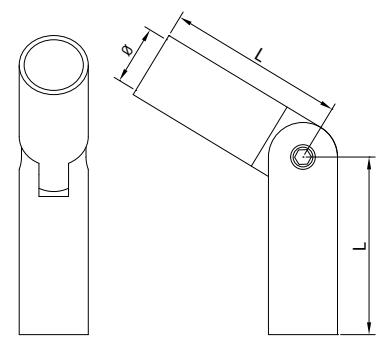

± 90° adjustable



COD.	D	L
AX10.010.081.A.SP	12 mm	15 mm

Round tube end cap

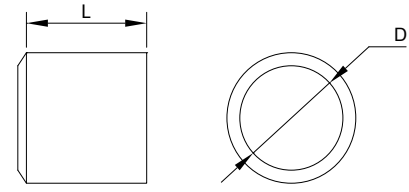
Weight:
 .011 kgs (.025 lbs)





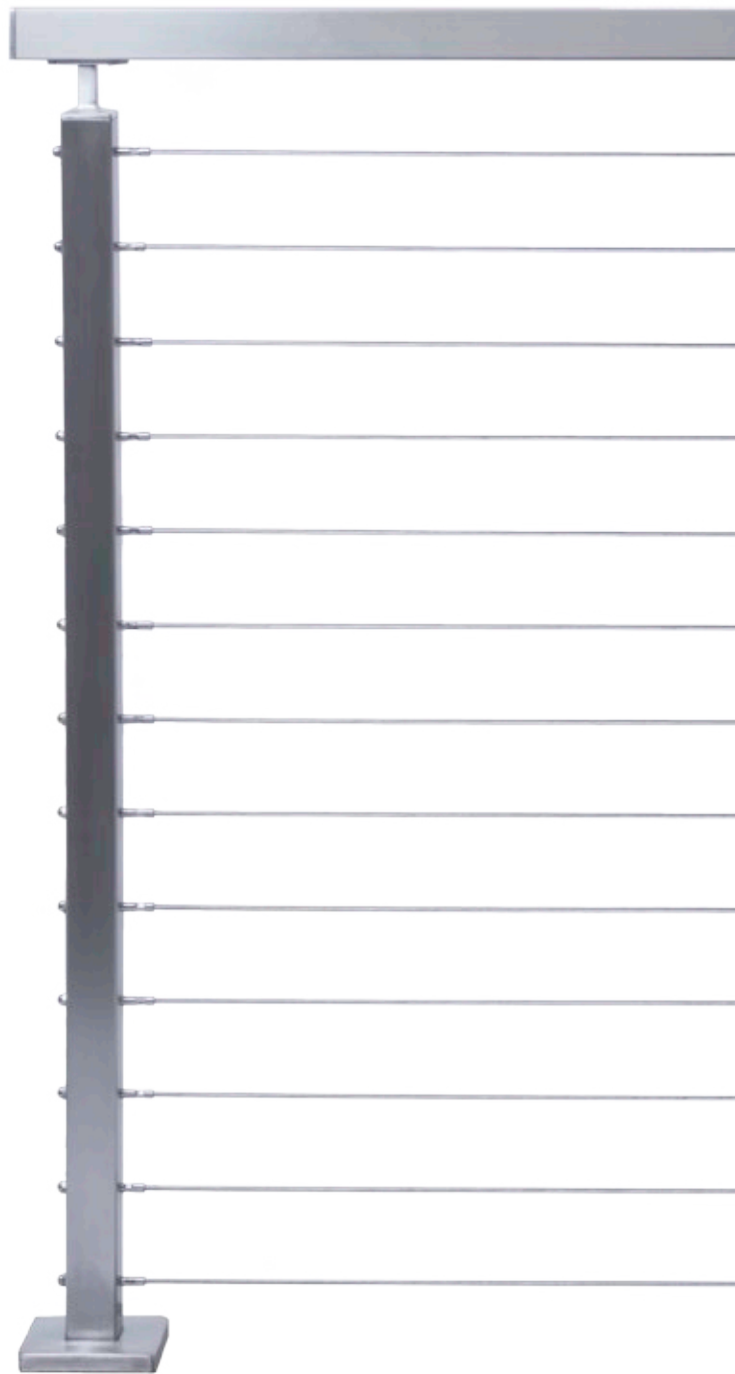





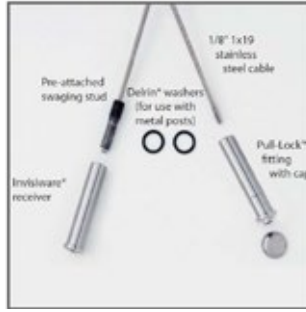

AISI 316



COD.	L	Wt.
HFC18.212-5	5'	.15 kgs (.331 lbs)
HFC18.212-10	10'	.227 kgs (.5 lbs)
HFC18.212-15	15'	.303 kgs (.669 lbs)
HFC18.212-20	20'	.383 kgs (.844 lbs)
HFC18.212-25	25'	.549 kgs (1.2 lbs)

Outside to outside
Level/balcony or angle/rake
Steel posts

Drill Kit AX00.070.640
Page 70



AISI 316



COD.	L	Wt.
HFC18.102-5	5'	.15 kgs (.331 lbs)
HFC18.102-10	10'	.227 kgs (.5 lbs)
HFC18.102-15	15'	.303 kgs (.669 lbs)
HFC18.102-20	20'	.383 kgs (.844 lbs)
HFC18.102-25	25'	.549 kgs (1.2 lbs)

Outside to outside
Level/balcony or angle/rake
Steel or wood posts

Drill Kit AX00.070.630
AX00.070.635 Page 70



AISI 316



COD.	L	Wt.
HFC18.401-5	5'	.15 kgs (.331 lbs)
HFC18.401-10	10'	.227 kgs (.5 lbs)
HFC18.401-15	15'	.303 kgs (.669 lbs)
HFC18.401-20	20'	.383 kgs (.844 lbs)
HFC18.401-25	25'	.549 kgs (1.2 lbs)

Inside to inside
Level/balcony

Drill Kit AX00.070.645
Page 70



AISI 316

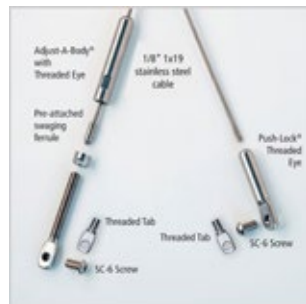

COD.	L	Wt.
HFC18.500M-5	5'	.15 kgs (.331 lbs)
HFC18.500M-10	10'	.227 kgs (.5 lbs)
HFC18.500M-15	15'	.303 kgs (.669 lbs)
HFC18.500M-20	20'	.383 kgs (.844 lbs)
HFC18.500M-25	25'	.549 kgs (1.2 lbs)

Inside to inside
Level/balcony or angle/rake

Drill Kit AX00.070.650
Page 70

AISI 316



1 x 19 Cable - 1/8" Diameter



AISI 316



COD.	L	Wt.
HFC18.262T-S-5	5'	.15 kgs (.331 lbs)
HFC18.262T-S-10	10'	.227 kgs (.5 lbs)
HFC18.262T-S-15	15'	.303 kgs (.669 lbs)
HFC18.262T-S-20	20'	.383 kgs (.844 lbs)
HFC18.262T-S-25	25'	.549 kgs (1.2 lbs)

Outside to outside Level/balcony

Drill Kit AX00.070.620
Page 70



AISI 316

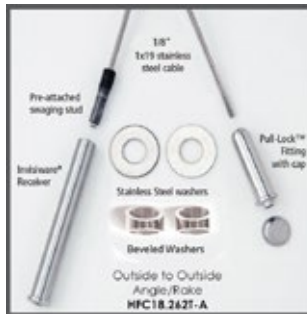

COD.	L	Wt.
HFC18.262T-A-5	5'	.15 kgs (.331 lbs)
HFC18.262T-A-10	10'	.227 kgs (.5 lbs)
HFC18.262T-A-15	15'	.303 kgs (.669 lbs)
HFC18.262T-A-20	20'	.383 kgs (.844 lbs)
HFC18.262T-A-25	25'	.549 kgs (1.2 lbs)

Outside to outside Angle/rake

Drill Kit AX00.070.620
Page 70



AISI 316

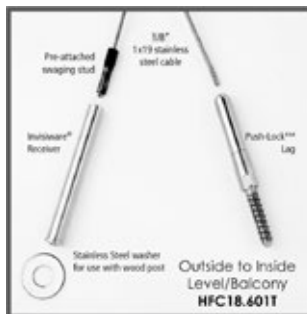

COD.	L	Wt.
HFC18.601T-A-5	5'	.15 kgs (.331 lbs)
HFC18.601T-A-10	10'	.227 kgs (.5 lbs)
HFC18.601T-A-15	15'	.303 kgs (.669 lbs)
HFC18.601T-A-20	20'	.383 kgs (.844 lbs)
HFC18.601T-A-25	25'	.549 kgs (1.2 lbs)

Outside to inside Level/balcony

Drill Kit AX00.070.627
Page 70



AISI 316



COD.	L	Wt.
HFC18.300-5	5'	.15 kgs (.331 lbs)
HFC18.300-10	10'	.227 kgs (.5 lbs)
HFC18.300-15	15'	.303 kgs (.669 lbs)
HFC18.300-20	20'	.383 kgs (.844 lbs)
HFC18.300-25	25'	.549 kgs (1.2 lbs)

Inside to inside Level/balcony

Drill Kit AX00.070.625
Page 70



AISI 316



COD.	L	Wt.
HFC18.500-5	5'	.15 kgs (.331 lbs)
HFC18.500-10	10'	.227 kgs (.5 lbs)
HFC18.500-15	15'	.303 kgs (.669 lbs)
HFC18.500-20	20'	.383 kgs (.844 lbs)
HFC18.500-25	25'	.549 kgs (1.2 lbs)

Inside to inside Angle/rake

Drill Kit AX00.070.625
Page 70



Page 70

AISI 316



Available in 328' spool

COD.	Dim. mm	Length	kg/100 m
AX00.040.215.B.M	4 mm	100 m	6.14

1x19 Cable - Bulk(4MM 316)

Weight:
8.5 kgs (18.73 lbs)

COD.	G	mm	L1	L2	L3	D	A	kg/100
AX00.050.220DX.B.SP	M6	4.0	88.0	30.0	50.0	7.0	4.5	1.2

Right handed cable terminal stud (DX)

Weight:
.016 kgs (.035 lbs)

AISI 316

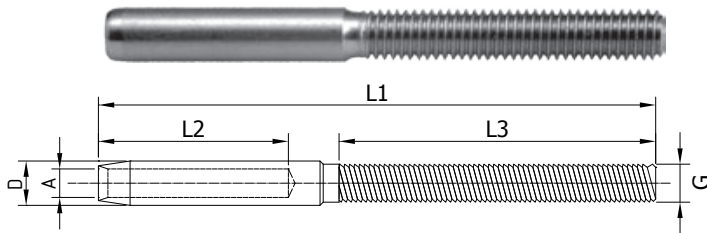

For use with 4mm cable

Hydraulic crimper



Page 72

Drill Kit **AX00.070.610**
Page 70

COD.	G	mm	L1	L2	L3	D	A	kg/100
AX00.050.221SX.B.SP	M6	4.0	88.0	30.0	50.0	7.0	4.5	1.2

Left handed cable terminal stud (SX)

Weight:
.016 kgs (.035 lbs)

AISI 316

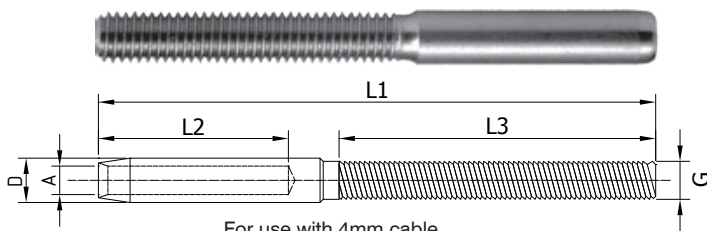

For use with 4mm cable

Hydraulic crimper



Page 72

Drill Kit **AX00.070.610**
Page 70

AISI 316



For use with 4mm cable

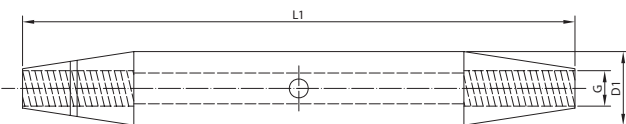

COD.	G	L1	D1	kg/100
AX00.050.235.B.SP	M6	65.0	10.0	1.7

Middle-tensioning body

Weight:
.025 kgs (.055 lbs)



COD.	NV	G	kg/100
AX00.050.231SX.B.SP	10	M6	0.9 LEFT
AX00.050.230DX.B.SP	10	M6	0.9 RIGHT

AISI 316

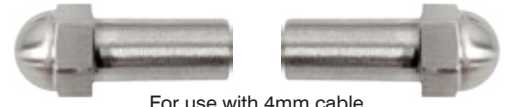

For use with 4mm cable

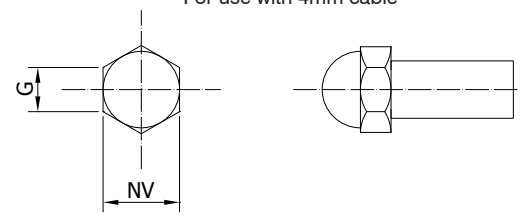

Threaded nut cap tensioners

Weight:
.006 kgs (.013 lbs)

Drill Kit **AX00.070.610**
Page 70



COD.	d	Ø	e
AX20.060.245.B.SP	12 mm	42.4 mm	14 mm FLAT

Sloping washer

Weight:
.006 kgs (.013 lbs)

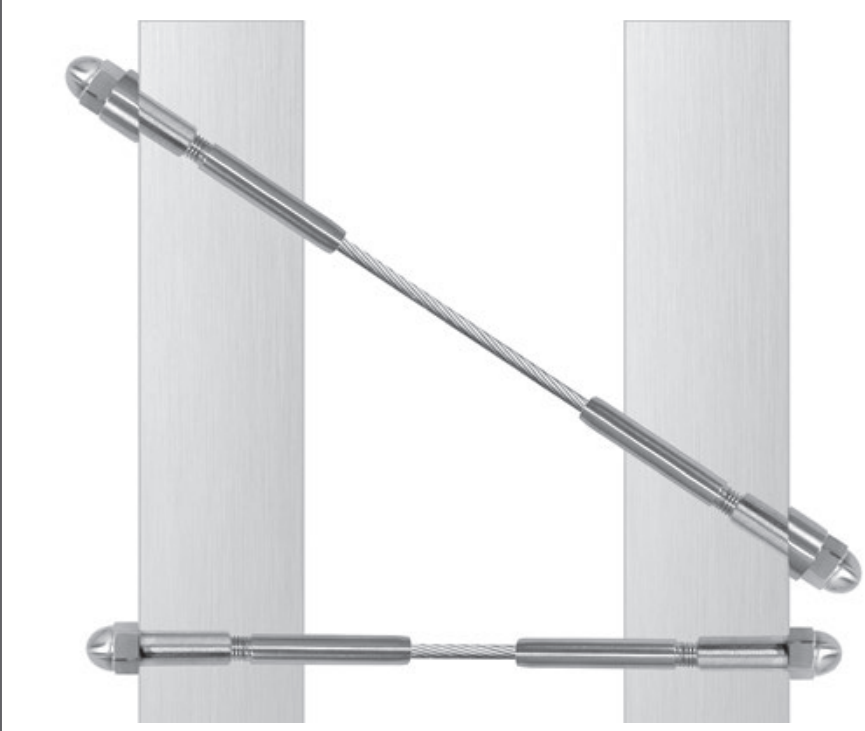
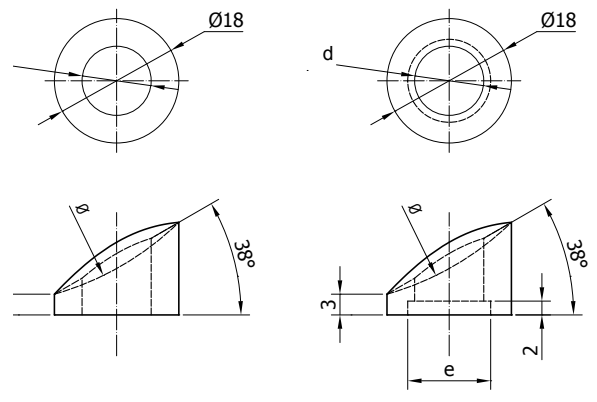



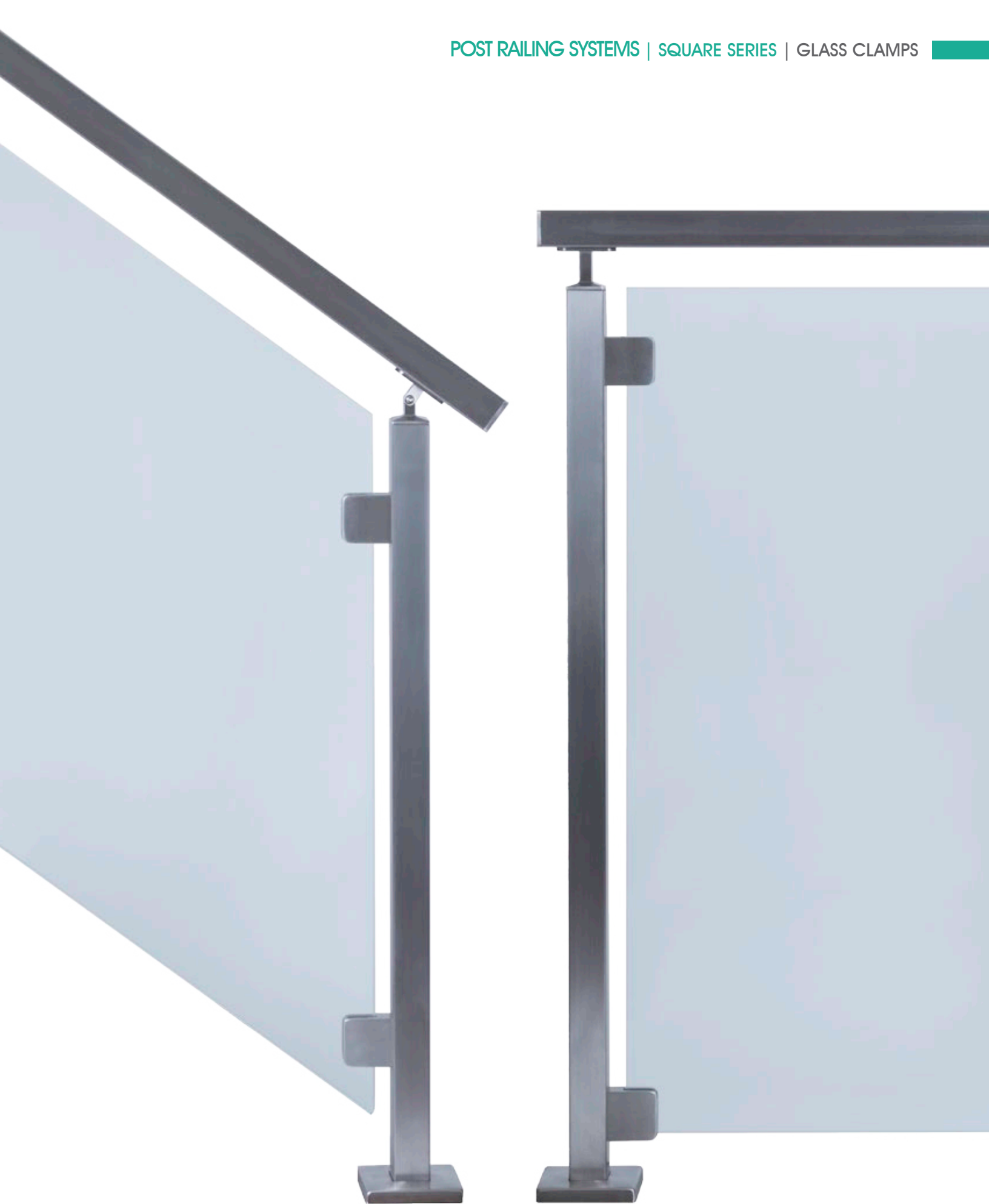

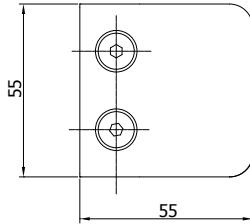
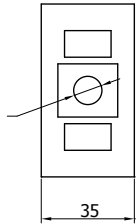
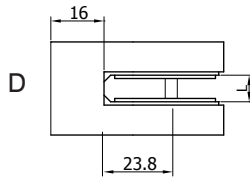
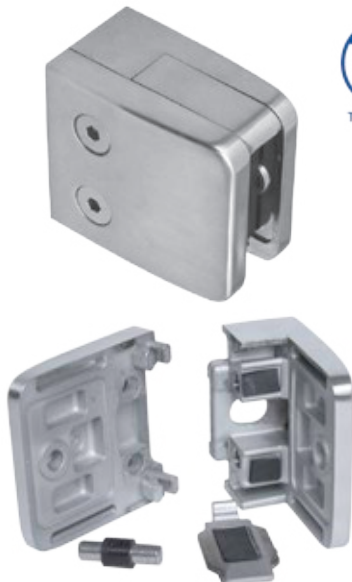

Note: All glass on stairways and balconies are considered a hazardous location and requires the use of tempered glass.

Note: Refer to page 16 for installation information

Swift plate and safety pin included

Note: Safety pin or swift plate can be used to support glass.

COD.	D	L
AX20.014.190.A.SP	flat	10 - 12.76 mm

Glass clamps for flat posts

Weight:
.328 kgs (.727 lbs)

Rubber inserts not included
Available for 3/8" & 1/2" monolithic glass

Quick# 255X, 830X
Page 68
1 per location



sold in pairs

COD.	T
AX20.014.191.R	10 mm for 3/8" glass
AX20.014.192.R	12 mm for 1/2" glass

Glass clamp inserts

T - indicates glass thickness

Weight:
.009 kgs (.02 lbs)



COD.	Size	ØD
AX00.090.266.A.SP	M5	6.9 mm
AX00.090.267.A.SP	M6	8.9 mm
AX00.090.269.A.SP	M8	10.9 mm

Pop rivets - threaded inserts

Weight:
.0018 kgs (.004 lbs)
.0027 kgs (.006 lbs)
.0045 kgs (.01 lbs)

Provides stronger connection for all system screws:
handrail, bar holders and glass clamps
No tapping Required

Quick# 250X, 255X,
260X Page 68

Sold individually



Pop rivet tool

Page 72

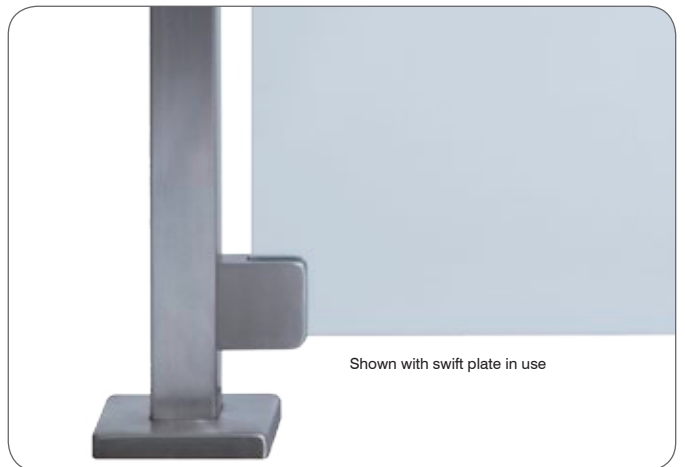

COD.	Ø	ØBase
AX20.001.010.A.SP	40 x 40 x 2 mm	100 x 100 mm

Square post

Weight:
3.03 kgs (6.66 lbs)

Quick# 800X, 805X
Page 68
2 per location

1000 mm (39-3/8")

COD.	H	Ø	Wt.
RO-4000	54"	3-1/4" x 3-1/4"	6.8 kgs (15 lbs)
RO-4923-41	41"	1-3/4" x 1-3/4"	.907 kgs (2 lbs)

Wood posts

S-9403, S-9401
Page 70
1 per location

COD.	H	Ø	Wt.
SQUARE-CAP-4000	2"	3-1/4" x 3-1/4"	.261 kgs (.57 lbs)

Post cap

Red Oak

1371.6 mm (54")

Flange cover included

Clear Silicone

See recommended tools section for information on cutting stainless steel.
www.axiarailing.com/recommended-tools

Clear Silicone

COD.	Ø
AX20.003.012.A.SP	105 mm

Replacement flange cover

Weight:
.147 kgs (.323 lbs)

COD.	Ø
AX20.001.011.A.SP	40 x 40 x 2 mm

Wall mount

Quick# 900X, 905X
Page 68
2 per location

Weight:
.727 kgs (1.6 lbs)

Note: Use square tube handrail for post (Page 42)

AX20.004.071.3000.A.SP
AX20.004.070.5800.A.SP

COD.	Ø	D
AX20.001.013.D.M	40 x 40 x 2 mm	
AX20.003.015.A.SP	105 mm	40 x 54.2 mm

Core mount

Weight:
.615 kgs (1.35 lbs)

For installation guidelines see page 18.

Epoxy



Clear Silicone

up to 40 degrees

Angled flange cover - core mount

Weight:
2.36 kgs (5.2 lbs)

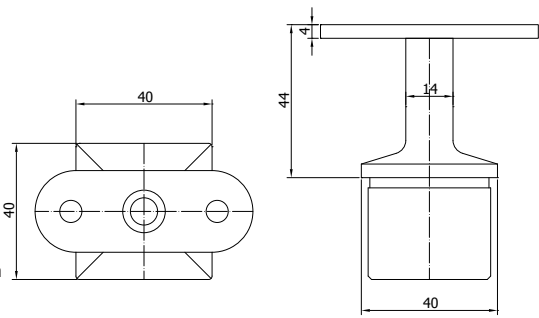

COD.	A	B
AX20.005.030.A.SP	flat	40 x 40 x 2 mm
Post handrail support		
Weight: .235 kgs (.517 lbs)		
 Option: Use M5 pop rivets to attach handrail AX00.090.266.A.SP		
2 per location		



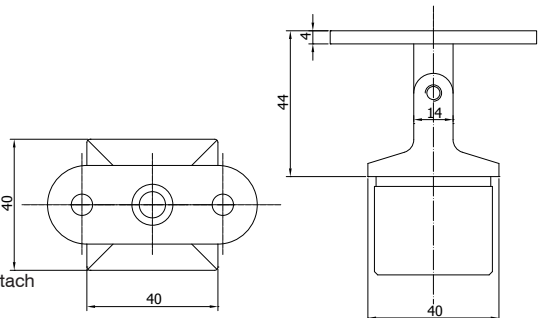
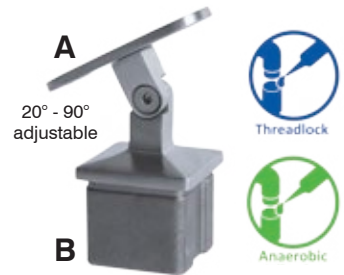

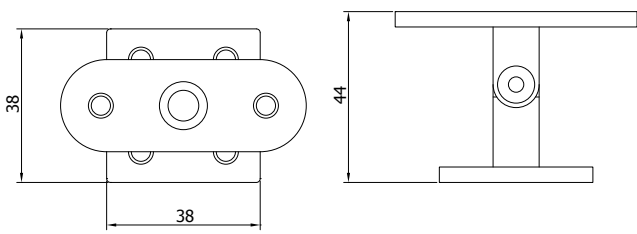

COD.	A	B
AX20.005.031.A.SP	flat	40 x 40 x 2 mm
Adjustable post handrail support		
Weight: .202 kgs (.444 lbs)		
 Option: Use M5 pop rivets to attach handrail AX00.090.266.A.SP		
2 per location		





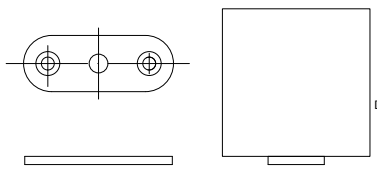

COD.	A	B
HF17.4001	flat	38 x 38 x 2 mm
Adjustable wood post handrail support		
Weight: .181 kgs (.4 lbs)		
 Option: Use M5 pop rivets to attach handrail AX00.090.266.A.SP		
2 per location		

COD.	D
AX10.005.025.A.SP	flat
Saddle	
Weight: .035 kgs (.077 lbs)	
 2 per location	

COD.	D
AX20.005.032.A.SP	flat
Saddle - 90 degree	
Weight: .036 kgs (.079 lbs)	
 2 per location	

COD.	Ø	L	Wt.
AX20.004.071.3000.A.SP	40 x 40 x 2 mm	3000 mm (9'-10")	7.5 kgs (16.5 lbs)
AX20.004.070.5800.A.SP	40 x 40 x 2 mm	5800 mm (19')	14.5 kgs (31.9 lbs)

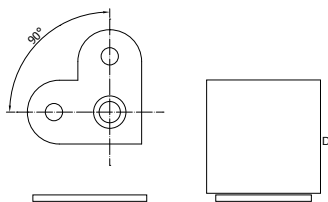
Square tube handrail/post



See recommended tools section for information on cutting stainless steel. www.axiarailing.com/recommended-tools

COD.	Ø	L	Wt.
RO-6084-20	2-5/8" x 1-5/8"	20'	13.61 kgs (30 lbs)
RO-6084-18	2-5/8" x 1-5/8"	18'	12.25 kgs (27 lbs)
RO-6084-16	2-5/8" x 1-5/8"	16'	10.89 kgs (24 lbs)
RO-6084-14	2-5/8" x 1-5/8"	14'	9.53 kgs (21 lbs)
RO-6084-12	2-5/8" x 1-5/8"	12'	8.16 kgs (18 lbs)
RO-6084-10	2-5/8" x 1-5/8"	10'	6.8 kgs (15 lbs)
RO-6084-8	2-5/8" x 1-5/8"	8'	5.44 kgs (12 lbs)
RO-6084-6	2-5/8" x 1-5/8"	6'	4.08 kgs (9 lbs)
RO-6084-4	2-5/8" x 1-5/8"	4'	2.72 kgs (6 lbs)
RO-6002-20	2-3/4" x 1-5/8"	20'	13.61 kgs (30 lbs)
RO-6002-18	2-3/4" x 1-5/8"	18'	12.25 kgs (27 lbs)
RO-6002-16	2-3/4" x 1-5/8"	16'	10.89 kgs (24 lbs)
RO-6002-14	2-3/4" x 1-5/8"	14'	9.53 kgs (21 lbs)
RO-6002-12	2-3/4" x 1-5/8"	12'	8.16 kgs (18 lbs)
RO-6002-10	2-3/4" x 1-5/8"	10'	6.8 kgs (15 lbs)
RO-6002-8	2-3/4" x 1-5/8"	8'	5.44 kgs (12 lbs)
RO-6002-6	2-3/4" x 1-5/8"	6'	4.08 kgs (9 lbs)
RO-6002-4	2-3/4" x 1-5/8"	4'	2.72 kgs (6 lbs)
RO-6060-16	2" x 1-1/16"	16'	3.63 kgs (8 lbs)
RO-6060-14	2" x 1-1/16"	14'	3.18 kgs (7 lbs)
RO-6060-12	2" x 1-1/16"	12'	2.72 kgs (6 lbs)
RO-6060-10	2" x 1-1/16"	10'	2.27 kgs (5 lbs)
RO-6060-8	2" x 1-1/16"	8'	1.81 kgs (4 lbs)



Additional species available by special order

Wood Handrail - Red Oak

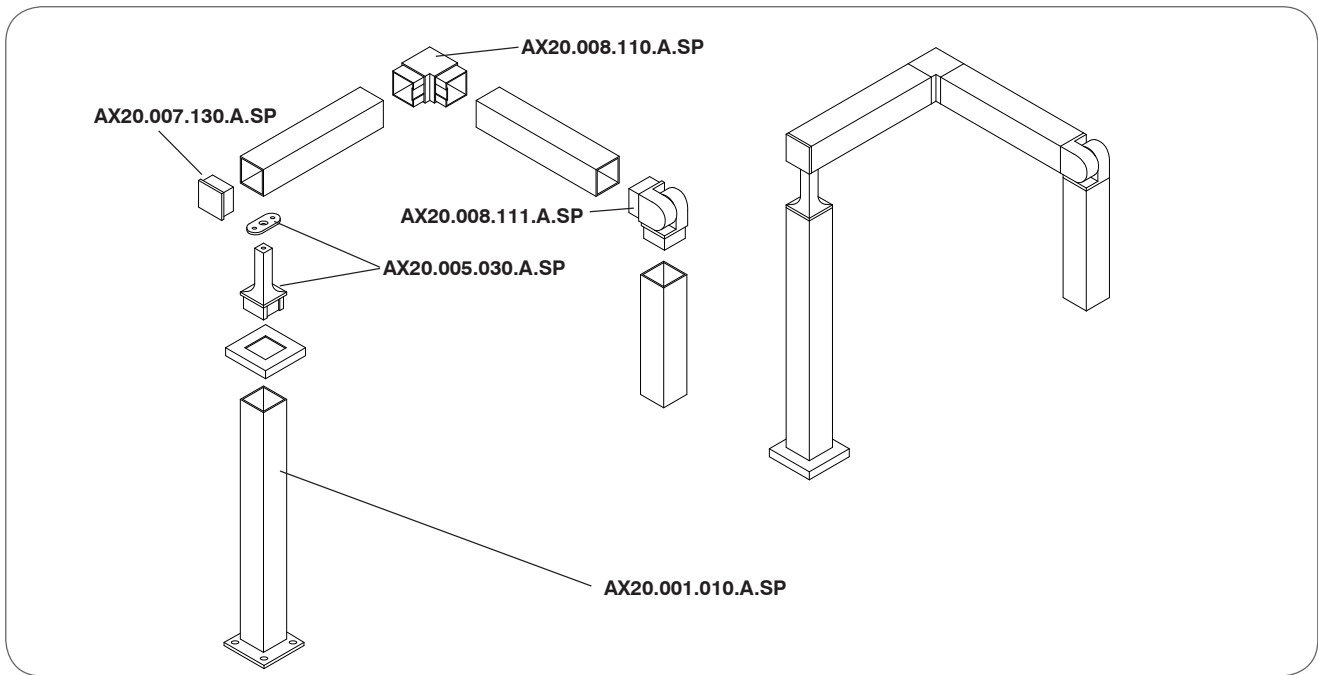

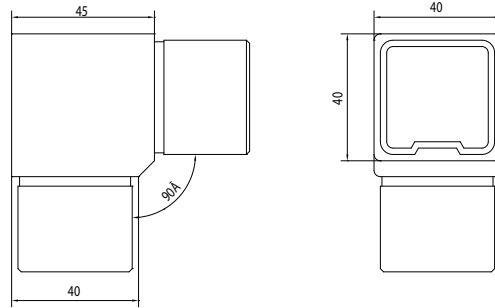

COD. \emptyset

AX20.008.110.A.SP 40 x 40 x 2 mm

90 Degree elbow

Weight:
.037 kgs (.184 lbs)



$\pm 90^\circ$ adjustable

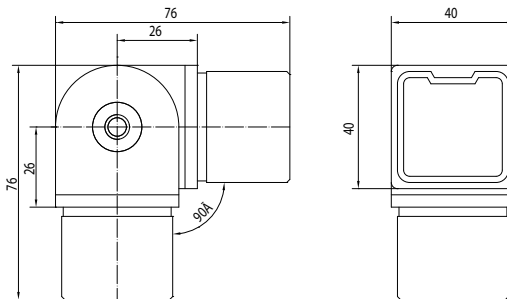

COD. \emptyset

AX20.008.111.A.SP 40 x 40 x 2 mm

Adjustable ± 90 degree elbow

Weight:
.546 kgs (1.2 lbs)

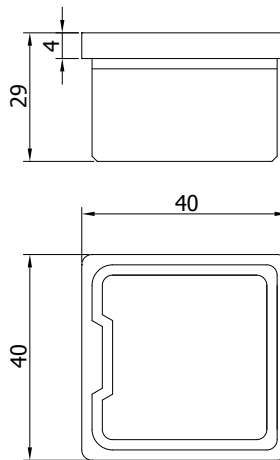
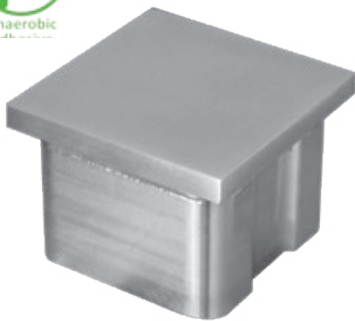

COD. \emptyset

AX20.007.130.A.SP 40 x 40 x 2 mm

End cap

Weight:
.1 kgs (.22 lbs)

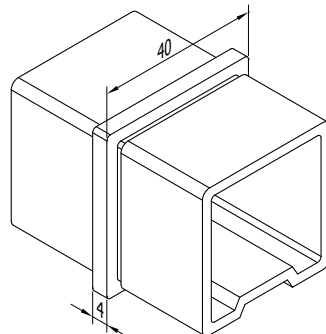
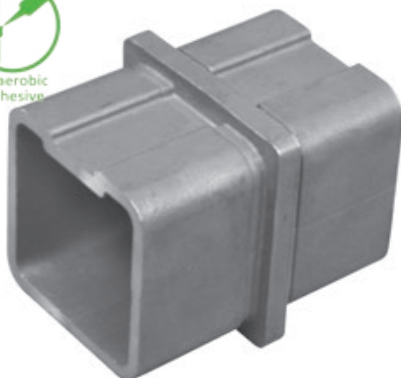

COD. \emptyset

AX20.008.112.A.SP 40 x 40 x 2 mm

Connector

Weight:
.155 kgs (.341 lbs)



Clear Silicone

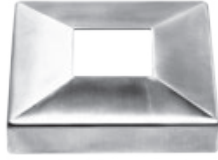

Flange cover included

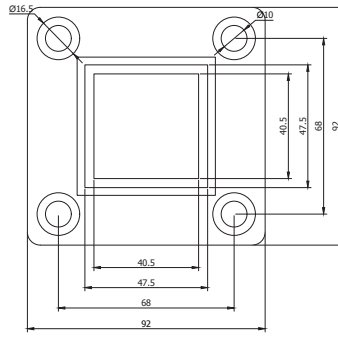

COD. Ø

AX20.008.150.A.SP 40 x 40 x 2 mm

Wall mount flange

Weight:
.578 kgs (1.27 lbs)

Quick# 830X
Page 68

4 per location

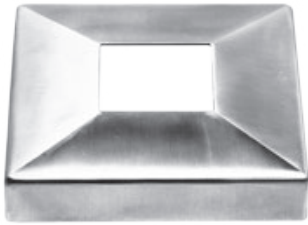

Clear Silicone

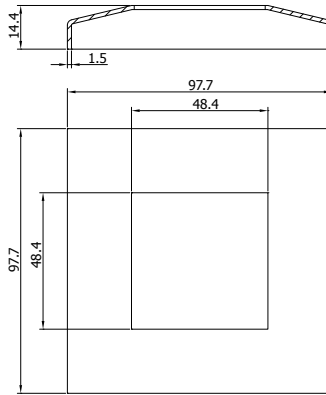

COD. Ø

AX20.008.151.A.SP 40 x 40 x 2 mm

Replacement cover for wall mount flange

Weight:
.108 kgs (.238 lbs)

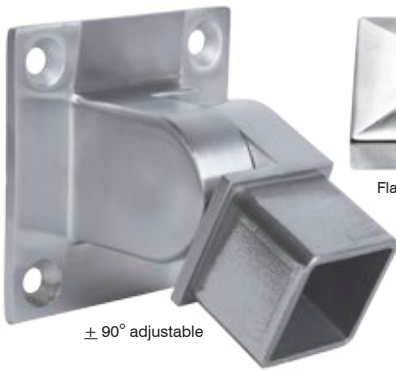

± 90° adjustable

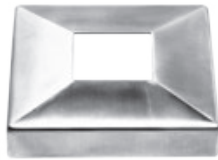

Flange cover included



Clear Silicone

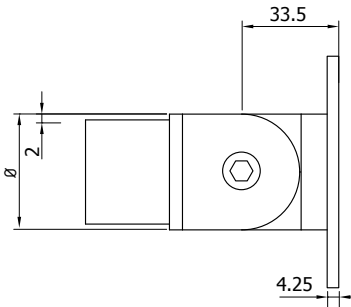

COD. Ø

AX20.008.152.A.SP 40 x 40 x 2 mm

Adjustable wall mount flange

Weight:
.794 kgs (1.75 lbs)

Quick# 830X
Page 68

4 per location

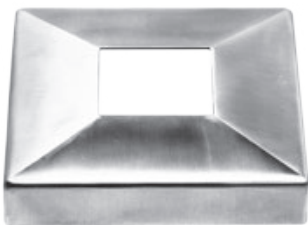
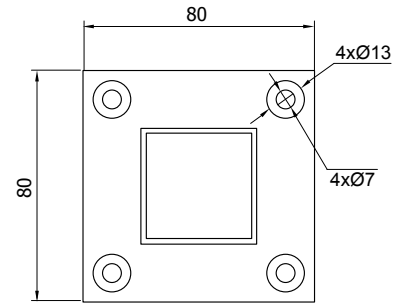

Clear Silicone

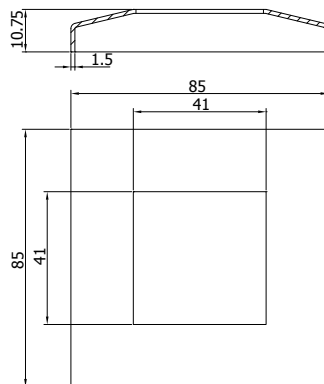

COD. Ø

AX20.008.153.A.SP 40 x 40 x 2 mm

Replacement cover for adjustable wall mount flange

Weight:
.078 kgs (.172 lbs)

COD. D

AX20.005.033.A.SP flat

Wall handrail support

Weight:
.328 kgs (.722 lbs)

Quick# 250X, 540X, 855X
Page 68

2 per location

COD. D

HF17.4002 flat

Wall handrail support

Weight:
.328 kgs (.722 lbs)

Quick# 250X, 540X
Page 68

2 per location

COD. D

AX20.005.035.A.SP flat

Post handrail support

Weight:
.375 kgs (.825 lbs)

Quick# 250X - 2 per location
Quick# 540X - 2 per location
Quick# 260X - 1 per location
Page 68

COD. D

AX20.005.034.A.SP flat

Glass handrail support

Weight:
.623 kgs (1.37 lbs)

Quick# 250X, 540X
Page 68

2 per location





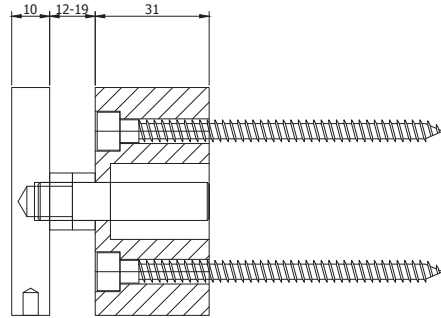
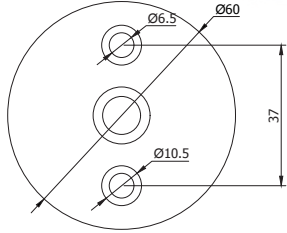
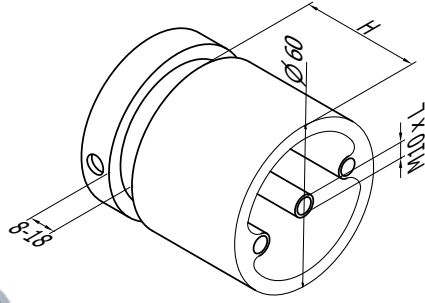

COD.	H	Glass Thickness
------	---	-----------------

AX30.017.040.A.SP 30.1 mm 8-18 mm

Glass standoff - round

Weight:
.543 kgs (1.17 lbs)

Quick# 900X, 905X
Page 68

2 per location



COD.	Thickness
------	-----------

AX30.017.042.F 1.25 mm

Glass leveling shim - round

Weight:
.011 kgs (.024 lbs)



Balcony

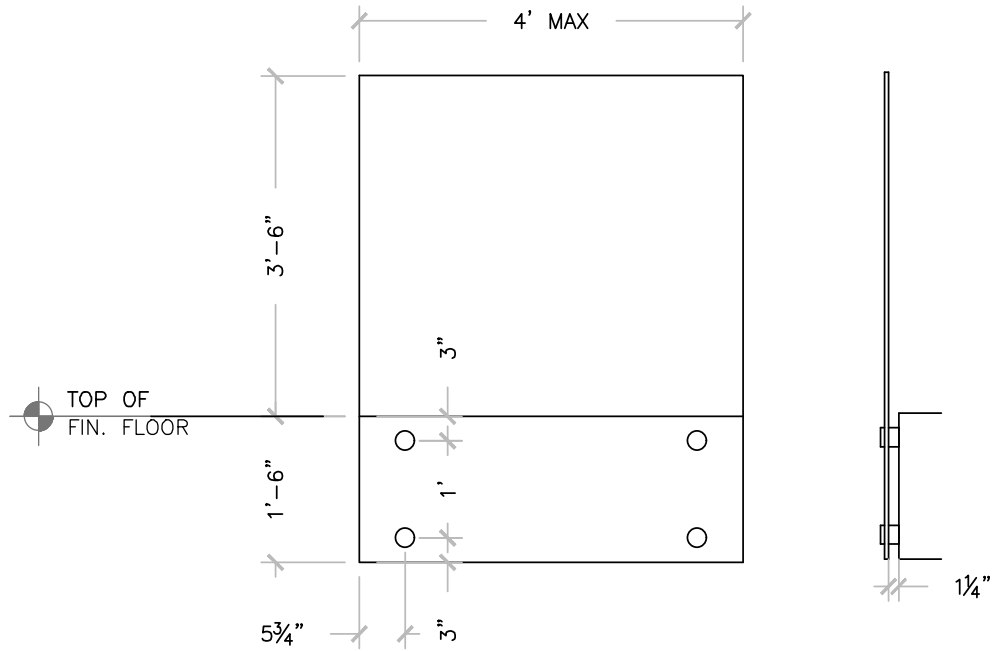

Stairs

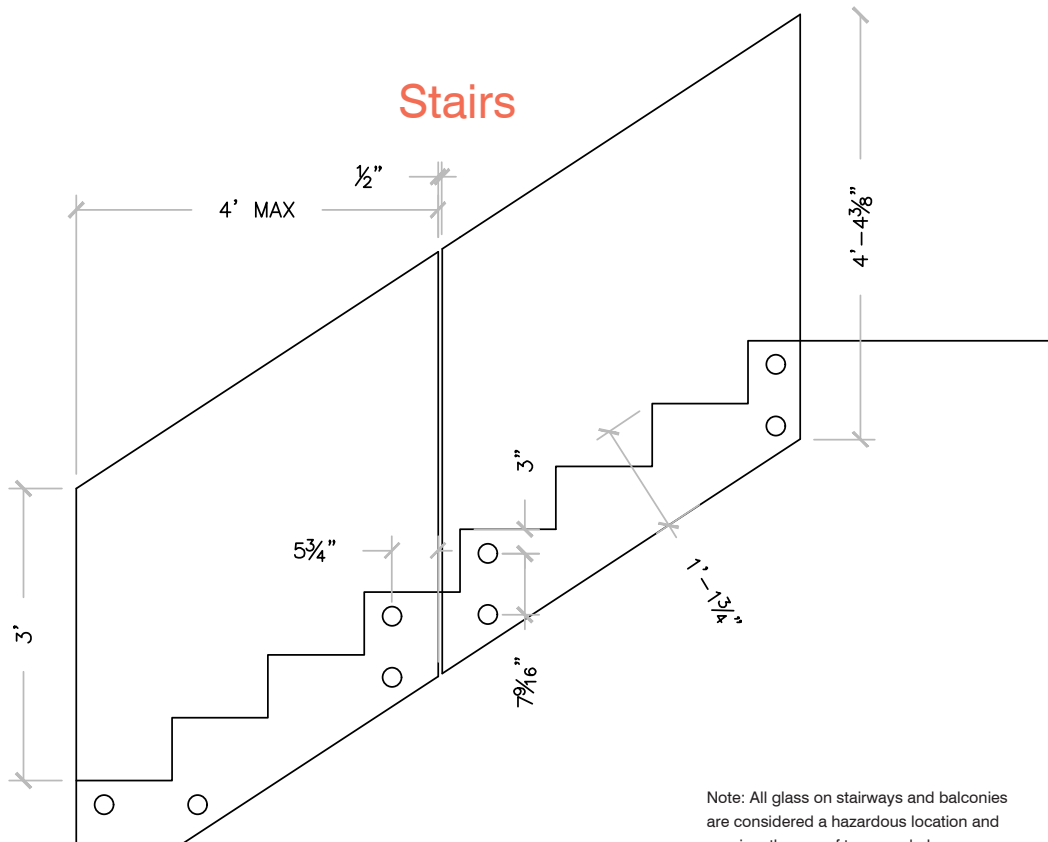

Cap rail required on glass for stairs to meet IRC code and recommended for balconies.
Check your local municipality for requirements

Note: All glass on stairways and balconies are considered a hazardous location and requires the use of tempered glass.

Note: Use flat polished edges on glass with radius or bumped corners when ordering glass from your glass supplier. All railing requires the use of tempered glass.





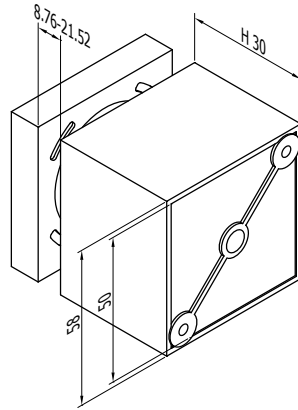

COD.	H	Glass Thickness
AX30.017.041.A.SP	30 mm	8.76 - 21.52 mm

Glass standoff - square

Weight:
.649 kgs (1.43 lbs)

Quick# 900X, 905X
Page 68

2 per location

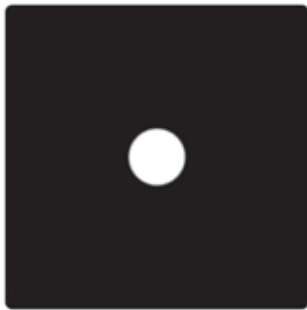
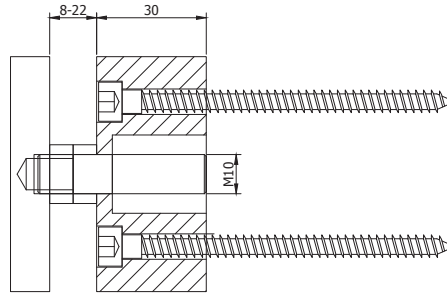
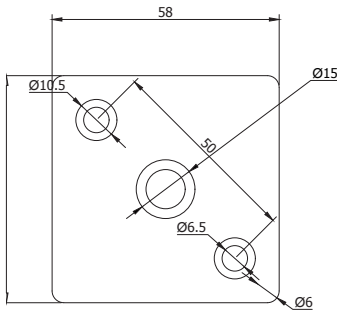

COD.	Thickness
AX30.017.043.F	1.25 mm

Glass leveling shim - square

Weight:
.013 kgs (.029 lbs)



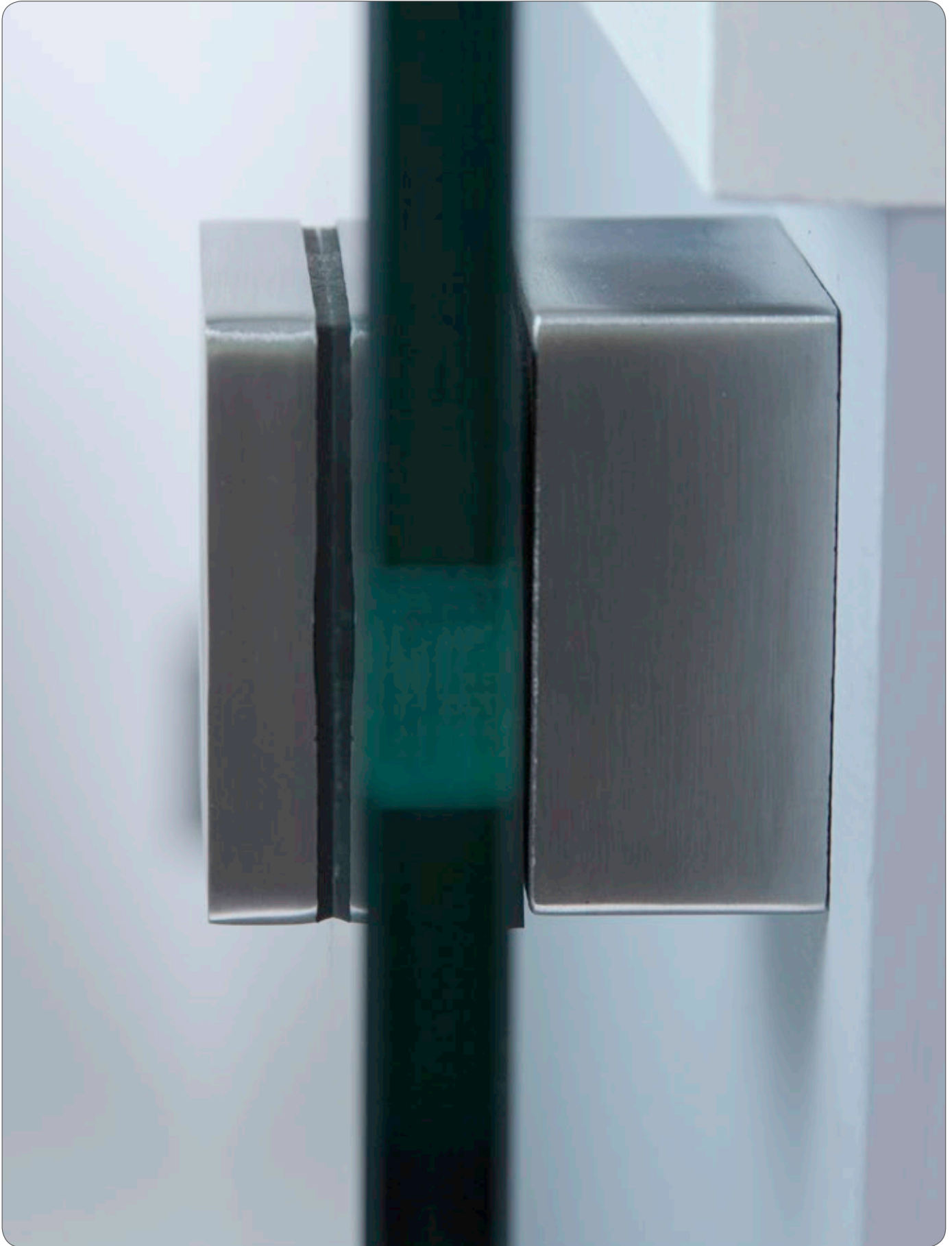



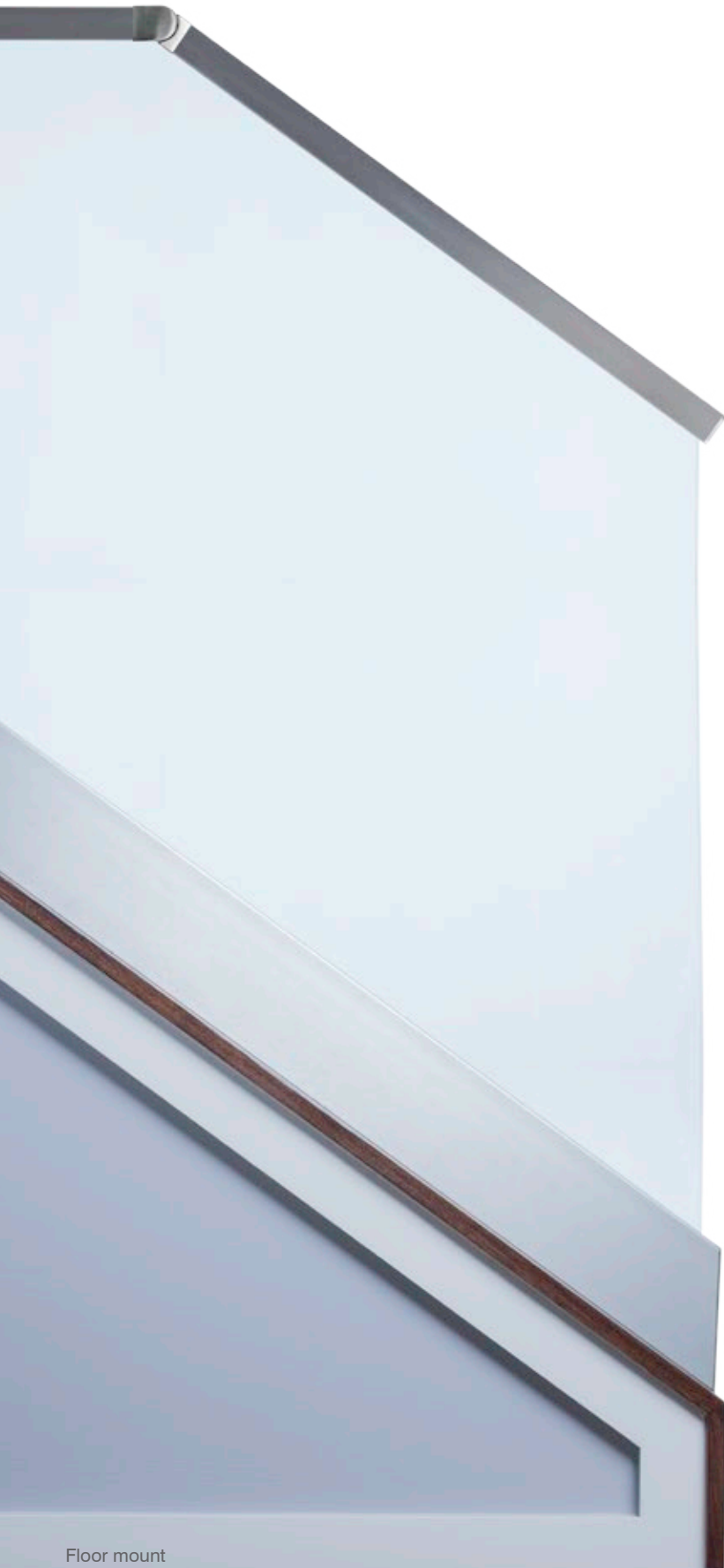



Floor mount



Wall mount

COD.	dim.	L.	Wt.
AX40.020.050.D.M	121 x 43 mm	5000 mm (16'-4")	24.59 kgs (54.78lbs)
Requires 2 glass gasket & wedge kits - Requires 25 anchors			
AX40.020.051.D.M	121 x 43 mm	2500 mm (8'-2")	12.45 kgs (27.39 lbs)
Requires 1 glass gasket & wedge kit - Requires 13 anchors			

Floor mount profile  Quick# 880X, 885X Page 68



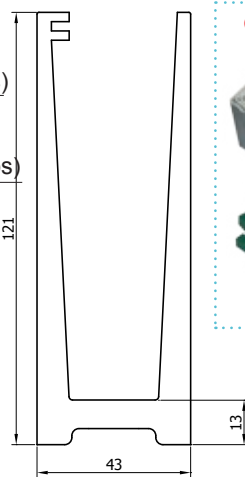

Satin Aluminum finish



C (10 pcs.) 

B (2.5m) 

D (10 pcs.) 

E (2.5m) 

See recommended tools section for information on cutting stainless steel. www.axiarailing.com/recommended-tools

For use with up to 3/4" glass. Gasket will only fit 1/2" glass. When using 3/4" glass Bronze Sealant is required to seal U channel to glass.

COD.	dim.	L.	Wt.
AX40.024.279.A.SP	123 mm	2500 mm	3.62 kgs (7.96 lbs)

Stainless steel cladding for floor profile

See recommended tools section for information on cutting stainless steel. www.axiarailing.com/recommended-tools



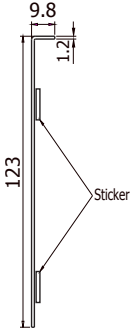

self adhesive



Sticker

COD.	dim.	L.	Wt.
AX40.020.052.D.M	119 x 45 mm	5000 mm (16'-4")	25.52 kgs (56.14 lbs)
Requires 2 glass gasket & wedge kits - Requires 19 anchors			
AX40.020.053.D.M	119 x 45 mm	2500 mm (8'-2")	12.76 kgs (28.07 lbs)
Requires 1 glass gasket & wedge kit - Requires 10 anchors			

Wall mount profile  Quick# 880X, 885X Page 68



AX40.020.055.D.SP
Hole plugs
For use when cladding will not be installed

Satin Aluminum finish

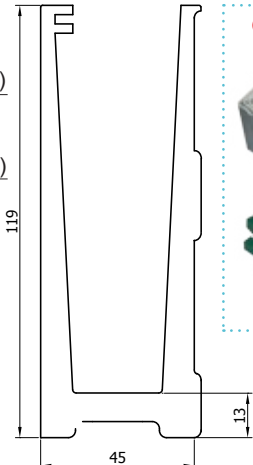

C (10 pcs.) 

B (2.5m) 

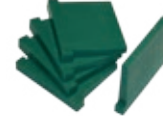
D (10 pcs.) 

E (2.5m) 

For use with up to 3/4" glass. Gasket will only fit 1/2" glass. When using 3/4" glass Bronze Sealant is required to seal U channel to glass.

COD.	dim.	L.	Wt.
AX40.024.280.A.SP	122 mm	2500 mm (8'-2")	3.62 kgs (7.96 lbs)

Stainless steel cladding for wall profile

See recommended tools section for information on cutting stainless steel. www.axiarailing.com/recommended-tools



self adhesive

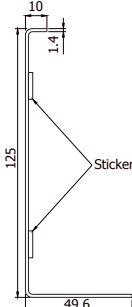

Sticker

COD.

AX40.021.285.R

Glass gasket & wedge kit

Wedge kits are not included with U Channel
This part is sold separately

Weight:
1.41 kgs (3.11 lbs)

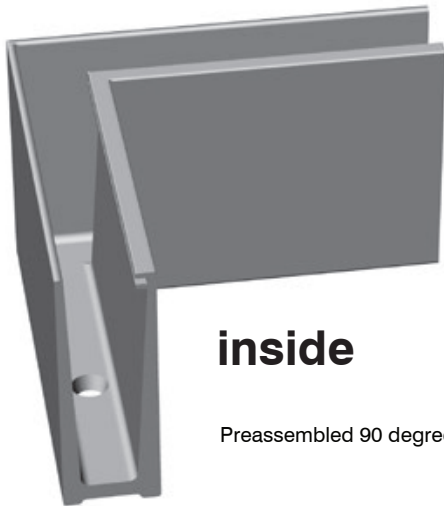
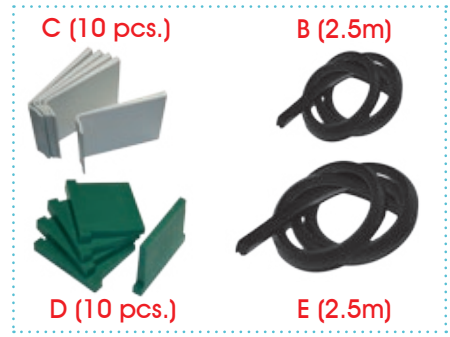

inside

Preassembled 90 degree corner

Floor profile

Quick# 880X, 885X
Page 68

2 per location

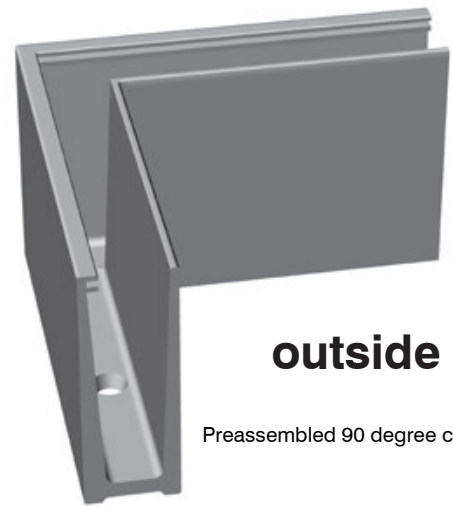

outside

Preassembled 90 degree corner

COD.	dim.	L.
------	------	----

AX40.023.272.D.M	120 x 45 mm	200 mm
Requires 2 anchors		
Inside corner for floor profile	Weight: 1.75 kgs (3.85 lbs)	

COD.	dim.	L.
------	------	----

AX40.023.274.D.M	120 x 45 mm	200 mm
Requires 2 anchors		
Outside corner for floor profile	Weight: 1.75 kgs (3.85 lbs)	



inside

Preassembled 90 degree corner

Wall profile

Quick# 880X, 885X
Page 68

2 per location

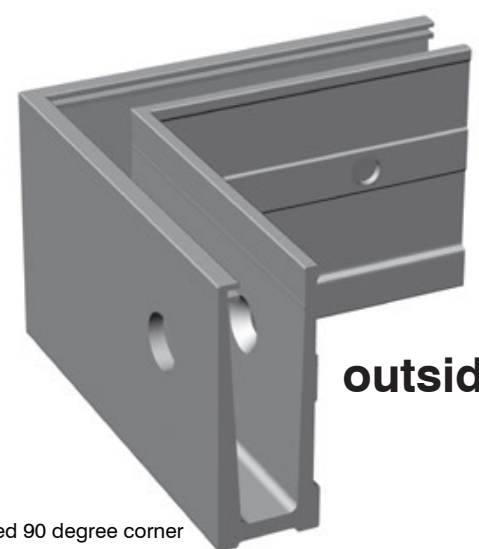

outside

Preassembled 90 degree corner

COD.	dim.	L.
------	------	----







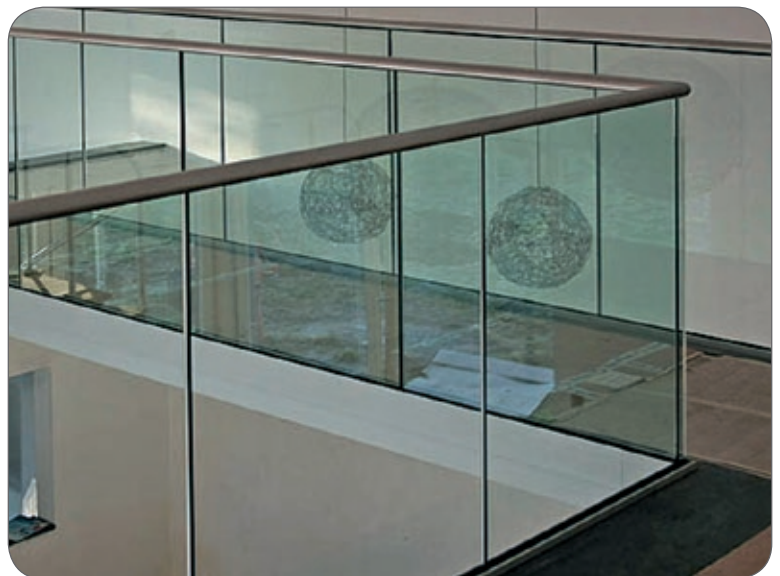
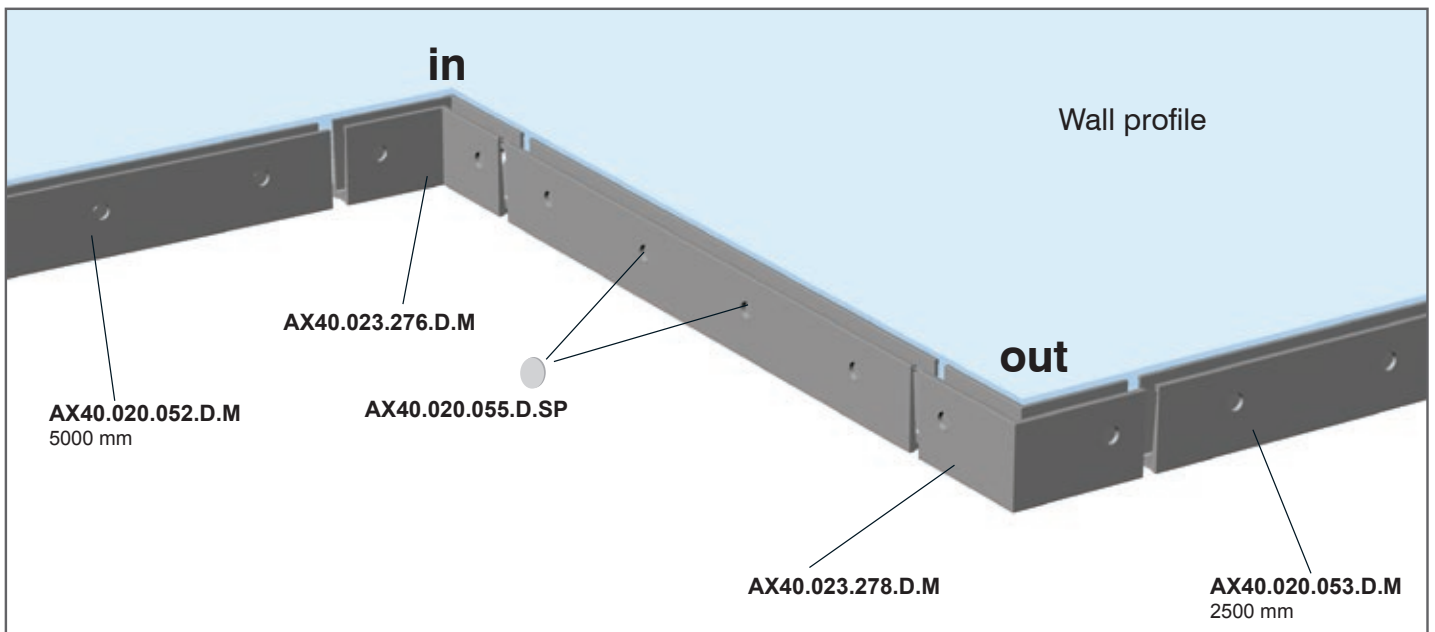
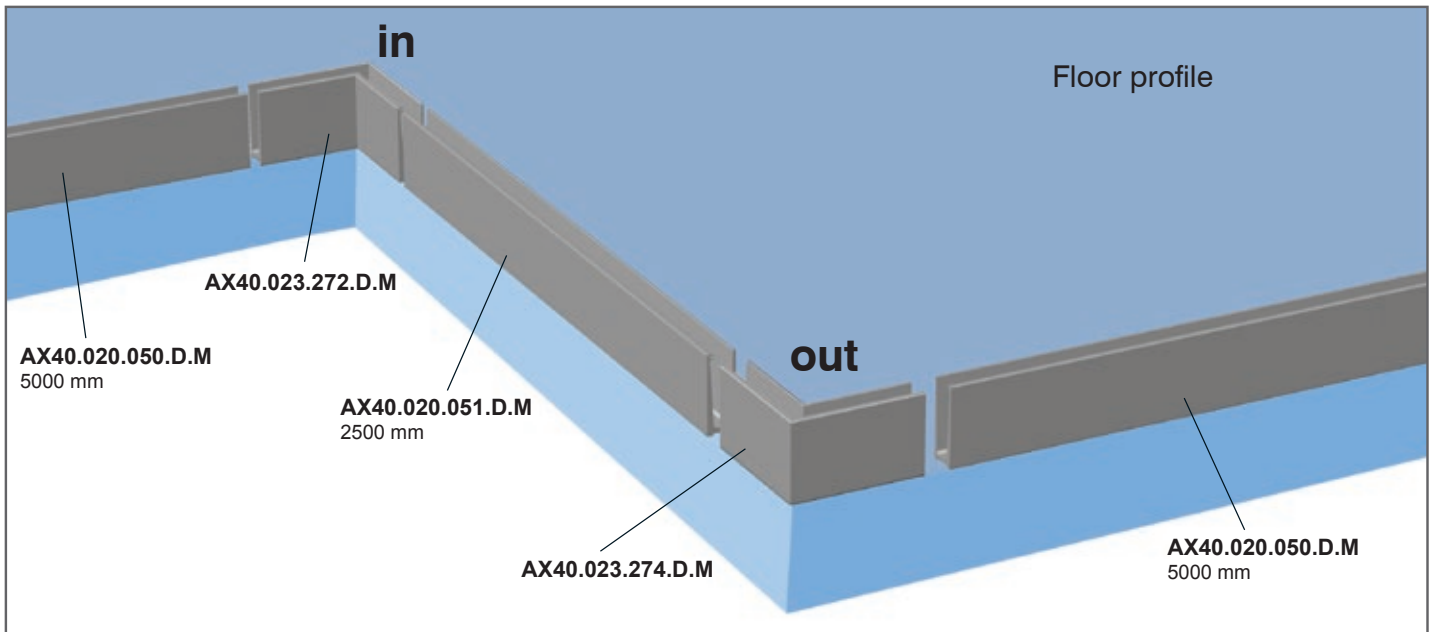

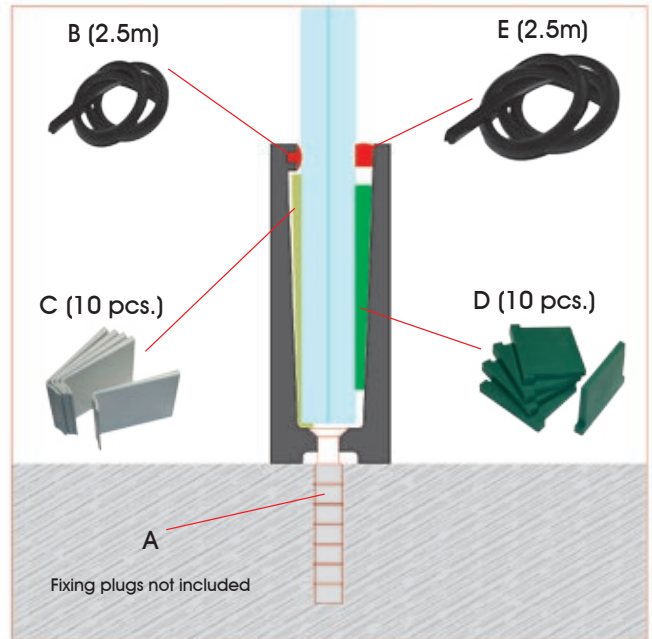
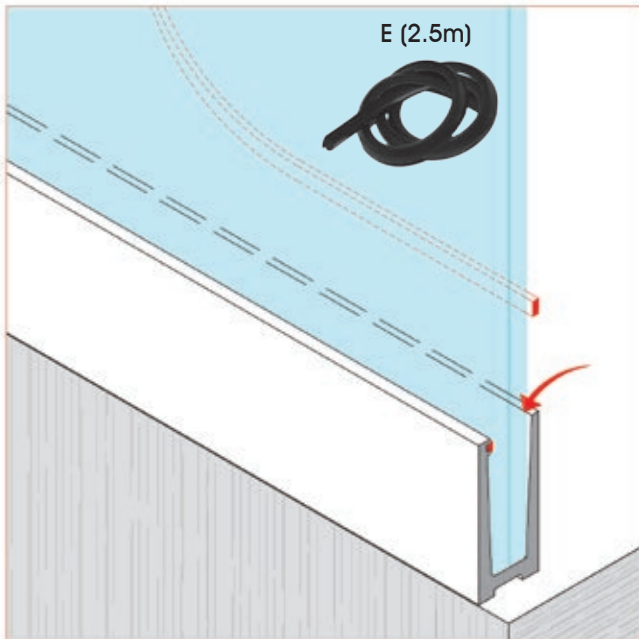
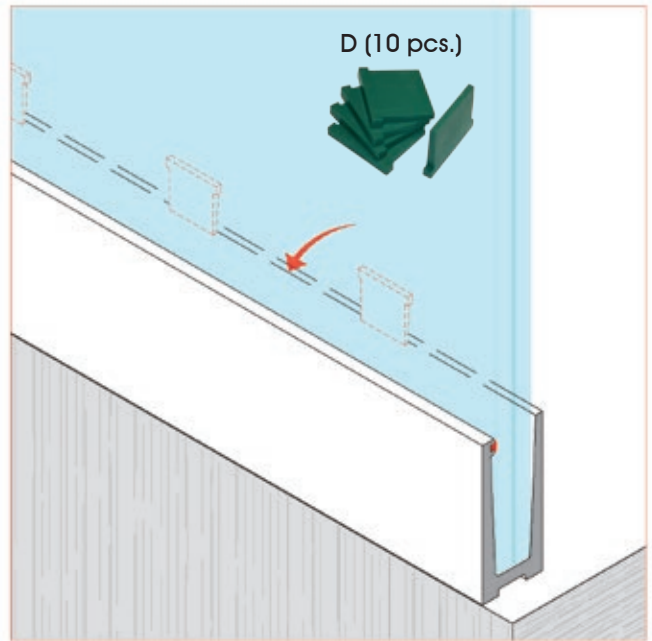
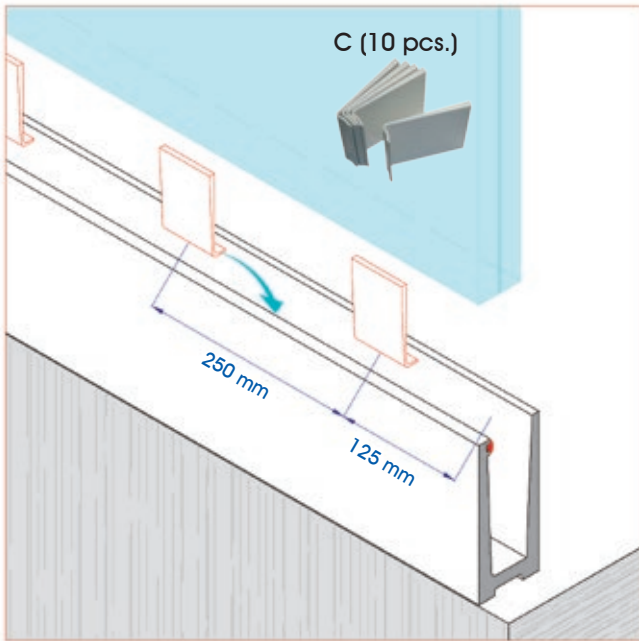
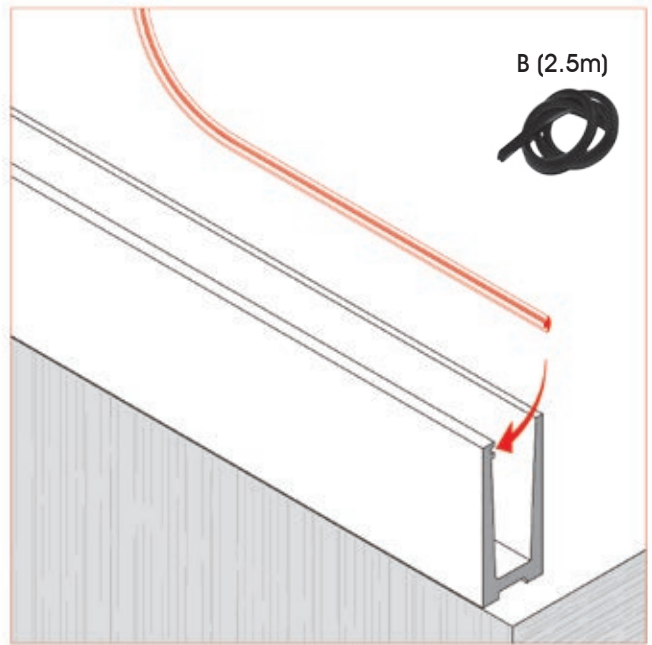
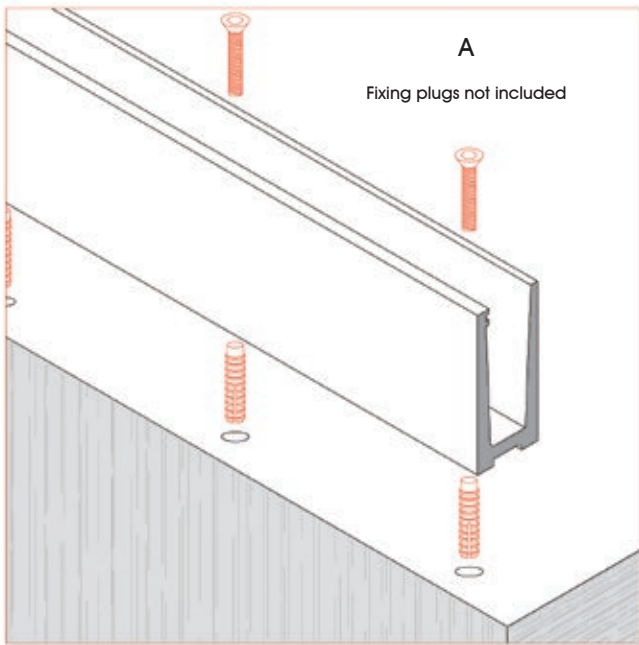

AX40.023.276.D.M	120 x 43 mm	200 mm
Requires 2 anchors		
Inside corner for wall profile	Weight: 1.79 kgs (3.95 lbs)	

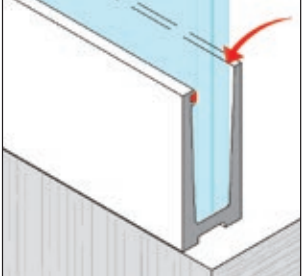
COD.	dim.	L.
------	------	----

AX40.023.278.D.M	120 x 43 mm	200 mm
Requires 2 anchors		
Outside corner for wall profile	Weight: 1.79 kgs (3.95 lbs)	



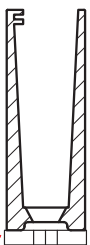

<p>COD.</p> <p><u>AX40.020.281.D.SP</u></p> <p>End cap - Floor profile - Level/balcony</p> <p>Weight: .02 kgs (.044 lbs)</p>	   <p>Satin Finish Aluminium</p>
<p>COD.</p> <p><u>AX40.020.283.D.SP</u></p> <p>End cap - Floor profile - Angle/rake</p> <p>up to 40 degrees</p> <p>Weight: .026 kgs (.057 lbs)</p>	  <p>Satin Finish Aluminium</p>
<p>COD.</p> <p><u>AX40.020.282.D.SP</u></p> <p>End cap - Wall profile - Level/balcony</p> <p>Weight: .021 kgs (.046 lbs)</p>	  <p>Satin Finish Aluminium</p>
<p>COD.</p> <p><u>AX40.020.284.D.SP</u></p> <p>End cap - Wall profile - Angle/rake</p> <p>up to 40 degrees</p> <p>Weight: .027 kgs (.059 lbs)</p>	  <p>Satin Finish Aluminium</p>
<p>COD.</p> <p><u>AX40.022.270.D.SP</u></p> <p>Drainage spacer</p> <p>Weight: .040 kgs (.087 lbs)</p> <p>For use on exterior balconies. Use one drainage spacer per hole. 25 per 5000mm(16'-4") U channel 13 per 2500mm(8'-2") U channel</p>	 

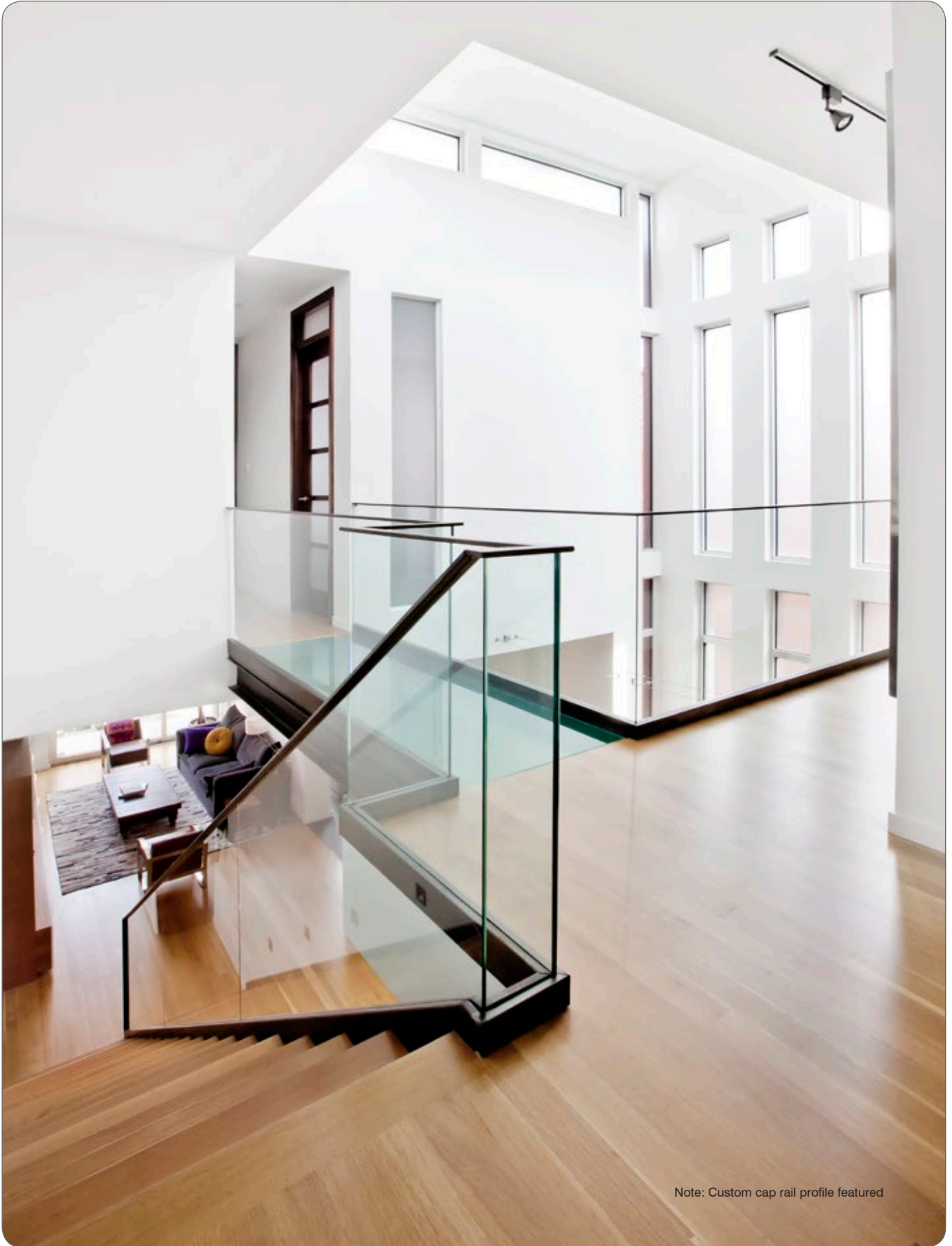

Note: Custom cap rail profile featured





COD.	Ø	T	X	L
AX00.030.065.A.SP	42.4 x 1.5 mm		24 x 24 mm	5000 mm (16'-4")

Rubber washer not included

Glass cap rail



Weight:
10.2 kgs (22.4 lbs)

AX00.031.072.R	42.4 x 1.5 mm	13.52 mm	24 x 24 mm	5000 mm (16'-4")
-----------------------	---------------	----------	------------	------------------

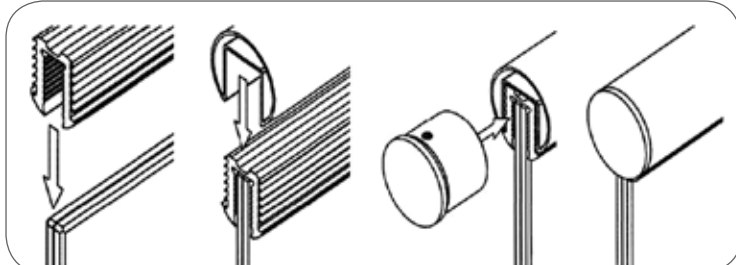

Rubber gasket

Weight:
2.34 kgs (5.15 lbs)

Apply clear silicone to glass before applying gasket, apply on top of gasket also before mounting cap rail.

For use with 3/8"-1/2" glass

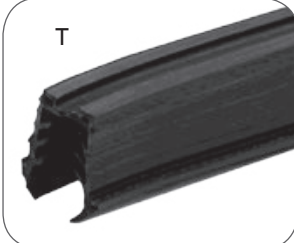
COD.	Ø
AX00.032.175.A.SP	42.4 x 1.5 mm

Wall mount flange

Weight:
.2 kgs (.44lbs)

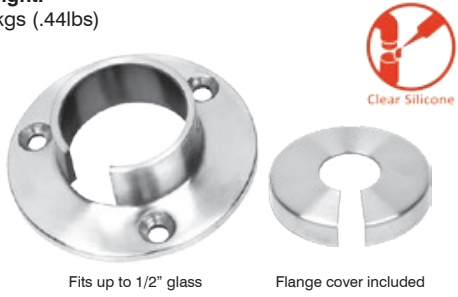

Fits up to 1/2" glass

Flange cover included



Quick# 820X
Page 68

3 per location

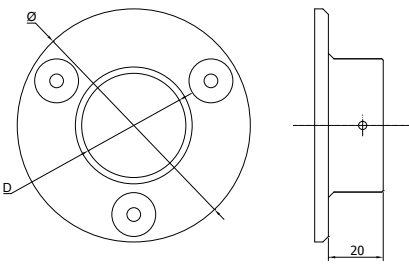

COD.	Ø
AX00.003.176.A.SP	42.4 x 1.5 mm











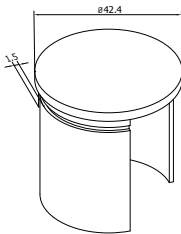

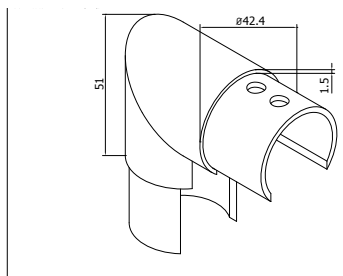
Replacement wall mount flange cover

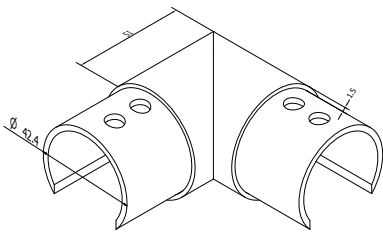
Weight:
.1 kgs (.219 lbs)

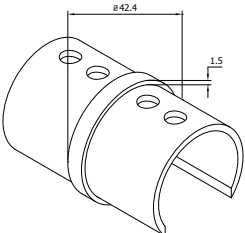

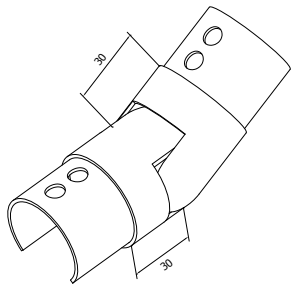

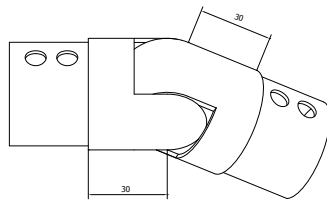

Slotted flange cover allows glass to be installed 1/4" from wall

<p>COD. \emptyset</p> <p>AX00.030.120.A.SP 42.4 x 1.5 mm</p> <p>Flat end cap</p> <p>Weight: .084 kgs (.184 lbs)</p>			
<p>COD. \emptyset</p> <p>AX00.032.171.A.SP 42.4 x 1.5 mm</p> <p>Vertical elbow</p> <p>Weight: .332 kgs (.73 lbs)</p>			
<p>COD. \emptyset</p> <p>AX00.032.170.A.SP 42.4 x 1.5 mm</p> <p>Horizontal elbow</p> <p>Weight: .297 kgs (.653 lbs)</p>			
<p>COD. \emptyset</p> <p>AX00.032.174.A.SP 42.4 x 1.5 mm</p> <p>Connector</p> <p>Weight: .104 kgs (.289 lbs)</p>			
<p>COD. \emptyset</p> <p>AX00.032.172.A.SP 42.4 x 1.5 mm</p> <p>Adjustable elbow - upward</p> <p>Weight: .3 kgs (.66 lbs)</p>			
<p>COD. \emptyset</p> <p>AX00.032.173.A.SP 42.4 x 1.5 mm</p> <p>Adjustable elbow - downward</p> <p>Weight: .321 kgs (.706 lbs)</p>			

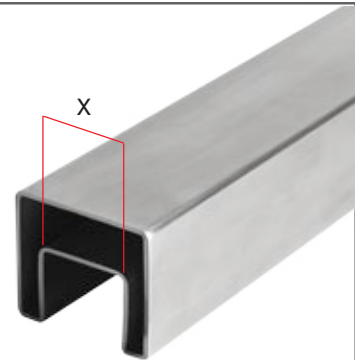
COD.	Ø	T	X	L
AX00.030.071.A.SP	42.4 x 1.5 mm		24 x 24 mm	5000 mm (16'-4")
Rubber washer not included				
Square cap rail				
Weight: 12.4 kgs (27.28 lbs)				
AX00.031.072.R	42.4 x 1.5 mm	13.52 mm	24 x 24 mm	5000 mm (16'-4")
Rubber washer				
Weight: 2.34 kgs (5.15 lbs)				
Apply clear silicone to glass before applying gasket, apply on top of gasket also before mounting cap rail.				

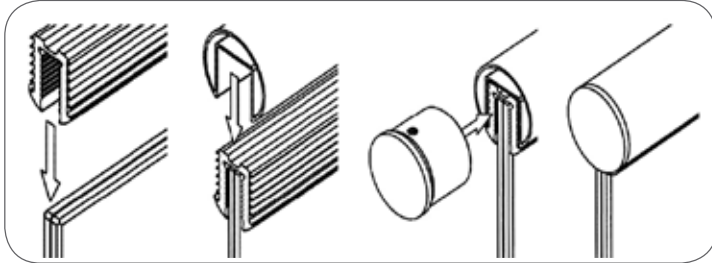
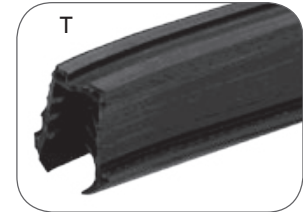

For use with 12mm(1/2") glass only



COD.	Ø	T	X	L	Wt.
AX00.030.073.G.RW	1.57" x 1.57"		24 x 24 mm	16'	5.81 kgs (12.8 lbs)
AX00.030.077.G.RW	1.57" x 1.57"		24 x 24 mm	14'	5.08 kgs (11.2 lbs)
AX00.030.076.G.RW	1.57" x 1.57"		24 x 24 mm	12'	4.35 kgs (9.6 lbs)
AX00.030.075.G.RW	1.57" x 1.57"		24 x 24 mm	10'	3.63 kgs (8 lbs)
AX00.030.074.G.RW	1.57" x 1.57"		24 x 24 mm	8'	2.9 kgs (6.4 lbs)
Red Oak wood cap rail Rubber washer not included					
AX00.030.080.H.RW	1.57" x 1.57"		24 x 24 mm	16'	5.81 kgs (12.8 lbs)
AX00.030.088.H.RW	1.57" x 1.57"		24 x 24 mm	14'	5.08 kgs (11.2 lbs)
AX00.030.087.H.RW	1.57" x 1.57"		24 x 24 mm	12'	4.35 kgs (9.6 lbs)
AX00.030.086.H.RW	1.57" x 1.57"		24 x 24 mm	10'	3.63 kgs (8 lbs)
AX00.030.084.H.RW	1.57" x 1.57"		24 x 24 mm	8'	2.9 kgs (6.4 lbs)

For use with 12mm(1/2") glass only

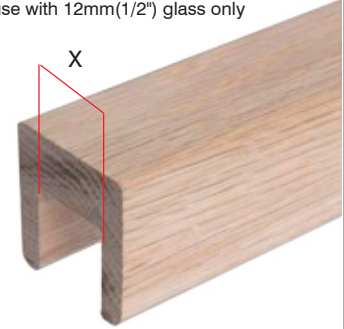

Additional species available by special order

White Oak wood cap rail Rubber washer not included

COD.	Ø
AX00.032.324.A.SP	42.4 x 1.5 mm

Wall mount flange

Weight:
.211 kgs (.464 lbs)

Quick# 820X
Page 68

2 per location

Clear Silicone

Flange cover included

COD.	Ø
AX00.003.325.A.SP	42.4 x 1.5 mm

Replacement wall mount flange cover

Weight:
.105 kgs (.231 lbs)

Clear Silicone











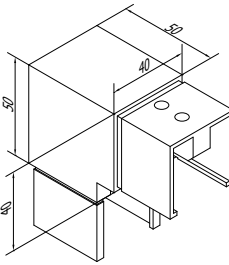

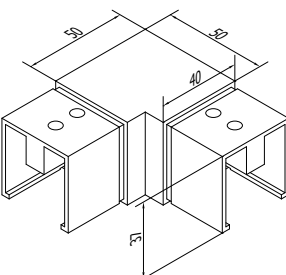
COD.	Ø
AX00.032.322.A.SP	42.4 x 1.5 mm

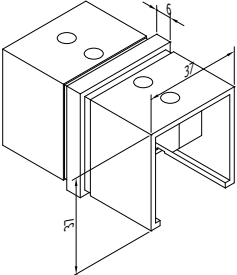
Flat end cap

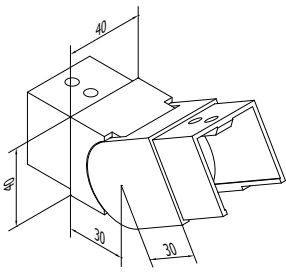

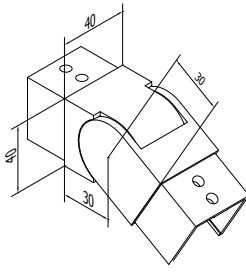

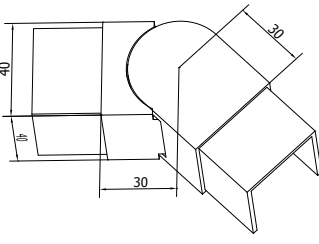



Weight:
.114 kgs (.251 lbs)

Anaerobic



<p>COD. Ø</p> <p>AX00.032.326.A.SP 42.4 x 1.5 mm</p> <p>Vertical elbow</p> <p>Weight: .428 kgs (.942 lbs)</p>		 
<p>COD. Ø</p> <p>AX00.032.305.A.SP 42.4 x 1.5 mm</p> <p>Horizontal elbow</p> <p>Weight: .367 kgs (.807 lbs)</p>		 
<p>COD. Ø</p> <p>AX00.032.320.A.SP 42.4 x 1.5 mm</p> <p>Connector</p> <p>Weight: .176 kgs (.387 lbs)</p>		 
<p>COD. Ø</p> <p>AX00.032.310.A.SP 42.4 x 1.5 mm</p> <p>Adjustable elbow - upward</p> <p>Weight: .411 kgs (.904 lbs)</p>		 
<p>COD. Ø</p> <p>AX00.032.311.A.SP 42.4 x 1.5 mm</p> <p>Adjustable elbow - downward</p> <p>Weight: .436 kgs (.962 lbs)</p>		 
<p>COD. Ø</p> <p>AX00.032.315.A.SP 42.4 x 1.5 mm</p> <p>Adjustable horizontal elbow</p> <p>Weight: .365 kgs (.803 lbs)</p>		 

System Hardware

	Quick#	Part#	Description	Application - Quantity Required
	250X	AX00.091.250.A.SP	M5 x 12 mm	Attaches saddle to metal handrail - 2 per
	540X	AX00.091.540.A.SP	4.8 x 25 mm	Attaches saddle to wood handrai - 2 per
	265X	AX00.091.265.A.SP	M6 x 10 mm	Attaches saddle to stem (Replacement) - 1 per
	260X	AX00.091.260.A.SP	M6 x 20 mm	Attaches bar holder to metal post - 1 per
	255X	AX00.091.255.A.SP	M8 x 25 mm	Attaches glass clamp to metal post - 1 per
	266X	AX00.091.266.A.SP	M5 Threaded Pop Rivet	Attaches glass clamp to metal post - 1 per
	267X	AX00.091.267.A.SP	M6 Threaded Pop Rivet	Attaches glass clamp to metal post - 1 per
	269X	AX00.091.269.A.SP	M8 Threaded Pop Rivet	Attaches glass clamp to metal post - 1 per

Anchors

	Quick#	Part#	Description	Application - Quantity Required
	800X	AX00.091.800.A.SP	3/8 x 3-1/2" Wood lag bolts	Round newel post mount - 3 per Square newel post mount - 2 per
	805X	AX00.091.805.A.SP	3/8 x 3-3/4" Concrete wedge anchors	Round newel post mount - 3 per Square newel post mount - 2 per
	820X	AX00.091.820.A.SP	#10 x 3" Wood screw to attach to wall	Round wall mount flange - 3 per Square cap rail wall mount flange - 4 per Round cap rail wall mount flange - 4 per
	830X	AX00.091.830.A.SP	#14 x 3" Wood screw to attach to wall	Round adjustable angle wall rail fitting - 3 per Square adjustable angle wall rail fitting - 4 per Square wall mount flange - 4 per Round wall Rail return - 3 per Round side mount post bracket - 2 per Square side mount post bracket - 2 per
	855X	AX00.091.855.A.SP	#12 x 3" Flat head wood screw	Round wall Rail Bracket - 3 per Square wall Rail Bracket - 2 per
	880X	AX00.091.880.A.SP	1/2 x 2-1/2" Flat head drop in anchor	U Channel 90 degree corners - 2 per U Channel floor / wall mount (2500mm) U Channel floor / wall mount (5000mm)
	885X	AX00.091.885.A.SP	#14 x 3" Wood screw to attach to wall/floor (includes 3/8" washer)	U Channel floor / wall mount (5000mm)
	900X	AX00.091.900.A.SP	M6 x 80 mm Wood screw with flat head (Phillips)	Standoffs / side mount post brackets - 2 per
	905X	AX00.091.905.A.SP	M6 x 85 mm Machine screw with socket head	Standoffs / side mount post brackets - 2 per

COD.

AX00.100.563



PERMABOND MH052 is ideal for the sealing of threaded joints. It is approved for use with gas for working pressure up to 26 bar and also for gaseous oxygen up to 10 bar and 60°C. MH052 seals against gas, water, LPG, hydrocarbons, oils and other chemicals. Unlike PTFE tape or hemp, Permabond MH052 will not shred or dry out, so it will provide a durable seal, helping to extend the life of the components. 75 ml

Thread Lock

Weight: .18 kgs (.4 lbs)



COD.

AX00.100.525



PERMABOND HM162 is a medium viscosity retaining compound that cures when confined between metal parts to form an extremely tough bond. It is best suited for cylindrical parts and where high temperature resistance is required. In the uncured, liquid state, the adhesive wets the metal surfaces, keying into all surface irregularities and fills the space between the mated parts. 50 ml

Anaerobic Adhesive

Weight: .136 kgs (.3 lbs)

COD.

EPC-410



Epoxy Adhesive, Rapid Cure, High Strength Paste, Translucent, 50mL, Cartridge, Mixing Ratio 1:1, Application Time 7 min., Functional Cure 4 Hrs, Full Cure 4 hr., Work Life 15 min., Substrates Metal, Wood, Brick, Stone, Marble, Rubber, Some Plastics, And More, Repairing and Bonding For Home, Farm, Office and Marine Automotive, Includes 2 Nozzles, Package Quantity 1

Two part epoxy

Weight: .114 kgs (.25 lbs)



COD.

EPC-101



Simultaneously mix and dispense 2-part adhesives. Holds 50 ml cartridges.

Epoxy gun

Weight: .179 kgs (.394 lbs)

COD.

S-2611



Titebond® 100% Silicone Sealant is a versatile formula that is ideal for both interior and exterior applications. It is a RTV industrial sealant and offers excellent adhesion to many common construction materials, including vinyl, aluminum, glass and painted surfaces. It also provides a strong, flexible seal that offers excellent water-resistance.

When fully cured, Titebond 100% Silicone Sealant can withstand extreme temperature conditions. The 100% antimicrobial formula will not crack or become brittle with age and resists fading or yellowing. It also extrudes easily in lower temperatures and dries quickly.

Clear Silicone Sealant

Weight: .365 kgs (.803 lbs)



COD.

AX00.080.505

- Superior alternative to steel wool, wire brushes, sandpaper, and other non-woven products for cleaning or finishing tasks.
 - Very fine grade aluminum oxide abrasive cleans, finishes, grains, denibs, and defuzzes.
 - Pad resists tearing, splintering, shredding, loading and will never rust, providing a long, useful life.
 - Can be folded, stacked, or rolled for effective cleaning or conditioning on flat, irregular, or contoured surfaces.
- Package of 2

Scotch Brite Pads

Weight: .116 kgs (.256 lbs)

COD.

AX00.080.515

Our strongest cleaner, ideal for removing hard to clean substances from all stainless steel products. Used most commonly after installation and prior to applying polish and passivator.

Degreaser

Weight: 108 kgs (.238 lbs)



Step 1



Step 2

COD.

AX00.080.510

Ideal for normal cleaning and maintenance of all stainless steel products. Use prior to applying passivator.

Cleaner/Polish

Weight: 108 kgs (.238 lbs)

COD.

AX00.080.517







Essential for maximum corrosion resistance of all stainless steel products. Use after applying degreaser and polish.

Polish/Passivator

Weight: 108 kgs (.238 lbs)



Step 3

<p>COD.</p> <p>AX00.070.640 212 Metal Post Drill Kit</p> <p>Includes: 5/32" Metal drill bit 29/64" Metal drill bit 3/16" Allen wrench</p> <p>Weight: .073 kgs (.16 lbs)</p>		<p>COD.</p> <p>AX00.070.620 262 Wood Post Drill Kit</p> <p>Includes: 5/32" Wood drill bit 29/64" Wood drill bit 1/4" Wood drill bit 3/16" Allen wrench</p> <p>Weight: .082 kgs (.18 lbs)</p>
<p>COD.</p> <p>AX00.070.635 102 Metal Post Drill Kit</p> <p>Includes: 5/32" Metal drill bit 9/32" Metal drill bit 29/64" Metal drill bit 7/16" Open end wrench 1/8" Allen wrench</p> <p>Weight: .091 kgs (.2 lbs)</p>		<p>COD.</p> <p>AX00.070.630 102 Wood Post Drill Kit</p> <p>Includes: 5/32" Wood drill bit 9/32" Wood drill bit 29/64" Wood drill bit 7/16" Open end wrench 1/8" Allen wrench</p> <p>Weight: .091 kgs (.2 lbs)</p>
<p>COD.</p> <p>AX00.070.645 401 Metal Post Drill Kit</p> <p>Includes: 5/16" Tap (24 thread) 5/16" Metal drill bit 5/32" Metal drill bit 7/16" Open end wrench 3/8" Open end wrench</p> <p>Weight: .091 kgs (.2 lbs)</p>		<p>COD.</p> <p>AX00.070.627 601 Wood Post Drill Kit</p> <p>Includes: 5/32" Wood drill bit 29/64" Wood drill bit 7/16" Open end wrench 3/16" Allen wrench</p> <p>Weight: .082 kgs (.18 lbs)</p>
<p>COD.</p> <p>AX00.070.650 500M Metal Post Drill Kit</p> <p>Includes: 5/16" Tap (24 thread) 5/16" Metal drill bit 5/32" Metal drill bit 7/16" Open end wrench 5/32" Allen wrench</p> <p>Weight: .091 kgs (.2 lbs)</p>		<p>COD.</p> <p>AX00.070.625 300,500 Wood Post Drill Kit</p> <p>Includes: 5/32" Wood drill bit 7/32" Wood drill bit 3/8" Open end wrench 7/16" Open end wrench 3/8" Allen wrench</p> <p>Weight: .091 kgs (.2 lbs)</p>
<p>COD.</p> <p>AX00.070.610 Bulk Cable & Fittings Drill Bit</p> <p>Includes: 5/16" Kobalt drill bit</p> <p>Weight: .023 kgs (.05 lbs)</p>		<p>COD.</p> <p>AX00.070.605 M5mm drill & tap set (handrail) AX00.070.606 M6mm drill & tap set (bar holders) AX00.070.608 M8mm drill & tap set (glass clamps)</p> <p>Drill & tap set</p> <p>Weight: .045 kgs (.1 lbs)</p>
<p>COD.</p> <p>AX00.070.651 1/2" punch for precision drilling.</p> <p>Center punch</p> <p>Weight: .068 kgs (.15 lbs)</p>		<p>COD.</p> <p>S-9403 Sure tite fastener for wood newel posts. Sure Tite Newel Fastener</p> <p>Weight: .249 kgs (.55 lbs)</p> <p>S-9401 Key lock fastener for wood newel posts. Key Lock Newel Fastener</p> <p>Weight: .301 kgs (.66 lbs)</p>
<p>COD.</p> <p>AX00.070.652 Tap Magic Pro Tap 16 oz spout top.</p> <p>Cutting fluid</p> <p>Weight: .454 kgs (1 lbs)</p>		<p>AX00.110.710 Composite shims for proper post leveling/mounting.</p> <p>Shims (12 pack)</p> <p>Weight: .331 kgs (.73 lbs)</p>

COD.

HFC18.C9CUTTER

Ideal for cutting our stainless steel cable or any cable up to 1/4" thickness.

Cable cutter - large

Weight:
.86 kgs (1.89 lbs)



COD.

HFC18.CUTTER

Ideal for cutting our stainless steel cable or any cable up to 1/8" thickness

Cable cutter - small

Weight:
.344 kgs (.74 lbs)



COD.

HFC18.WHEEL

Make close cuts on cable with clean finished ends.

Cable cut-off wheel

Weight:
.085 kgs (.187 lbs)



COD.

HFC18.PLIERS

Cable gripping pliers for proper tensioning.

Cable gripping pliers

Weight:
.748 kgs (1.65 lbs)



COD.

HFC18.TENSION.GAUGE

Accurately measure tension on cable railing.

Tension Gauge

Weight:
.241 kgs (.53 lbs)



COD.

HFC18.TUBE

Insert tube for use with 1/8" cable and wood posts.

Insert Tube

Weight:
.005 kgs (.01 lbs)



COD.

HFC18.KEY

Release key for all push lock fitting cable kits.

Cable Release Key

Weight:
.005 kgs (.01lbs)



COD.

HFC18.DRIVER

Hanger bolt driver for use with our HFC18.500 cable kit

Hanger bolt driver

Weight:
.204 kgs (.45 lbs)





COD.

AX10.070.212

Accurately bend 12 mm round infill tubing for curved applications.

Infill tube bender

Weight:
.301 kgs (6.35 lbs)

COD.

AX00.060.400

Our two stage hydraulic swaging compression tool allows for up to 16 tons of pressure to be applied to cable fittings. Full die set included for 3, 4, 5, 6 mm .

Hydraulic Crimper

Weight:
4.2 kgs (9.25 lbs)



COD.

AX00.060.415

Die set for 3-4mm

AX00.060.420

Die set for 5-6mm

Die set

Weight:
.045 kgs (.1 lbs)

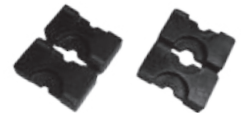

COD.

AX00.070.520

Threaded pop rivet installation gun. Interchangeable mandrel/nosepieces for blind rivet nuts sizes: M3,M4,M5,M6,M8

Pop rivet gun

Weight:
2.52 kgs (5.55 lbs)



COD.

AX30.070.530

Spanner wrench for tightening round standoffs.

Spanner wrench - round

Weight:
.187 kgs (.412 lbs)



COD.

AX30.070.531

Spanner wrench for tightening square standoffs.

Spanner wrench - square

Weight:
.295 kgs (.65 lbs)



COD.

AX40.070.562

This multi-function tool allows you to precisely hammer wedges into place and roll the rubber strip into place on U channel.

Wedge tool

Weight:
.68 kgs (1.5 lbs)



See our recommended tools section for information on cutting stainless steel. This section includes a complete range of tools that we highly recommend for professional installation.



Full Product Line Catalog Edition 001-B

